

## Proven Safety

### Safety Bumper

Safety Bumpers are protective devices comprising sensor(s), control device and output signal switching device(s).

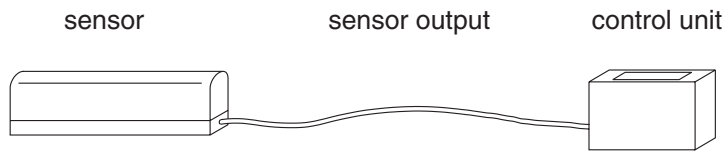

## Safety Bumpers 3.1.1 Product Range

The control unit is made up of control device and output signal switching device(s).

### Sensor

The sensor is that part of the Safety Bumper to which the actuating force is applied in order to produce a control command.

### Control device

The control device is that part of the Safety Bumper, which reacts to the status of the sensor and which produces those output signals which are transmitted to the machine control system.

The output signal switching device is that part of the control device which is connected to the machine control system and transmits safety output signals.

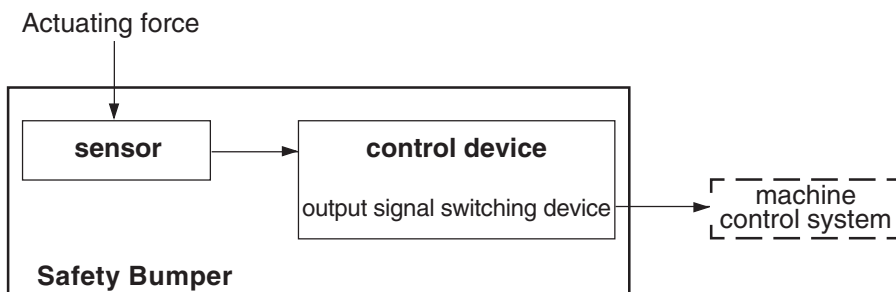

### The following points should be considered when choosing the sensors:

- temperature range
- response time
- protection class (standard: IP65)
- environmental considerations (oil, coolant, ...)

#### PLEASE NOTE:

The certification of design becomes invalid if our products are used in combination with control units or sensors which do not comply with the tested types.

Subject to technical modifications.

**2-wire-connection system  
(with monitoring resistor)**

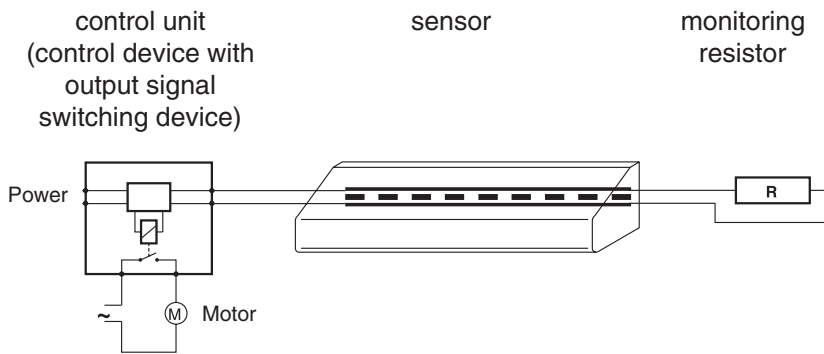

**Safety Bumpers 3.2.1  
Product Range**

The Safety Bumper comprises sensor control device and output signal switching device. The control device and the output signal switching device are combined in the control unit.

**Types**

- SB/BK through sensor with cable exit on both sides or for connecting up an external monitoring resistor
- SB/W with integrated monitoring resistor

For your safety:  
The sensor and the connecting cable are constantly monitored for function.  
A control function is attained by bridging the conductive areas with a monitoring resistor.

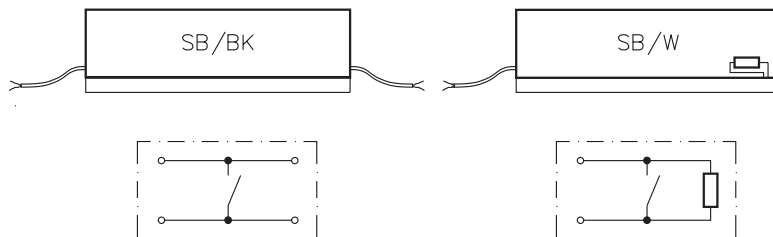

**Combination of sensors**

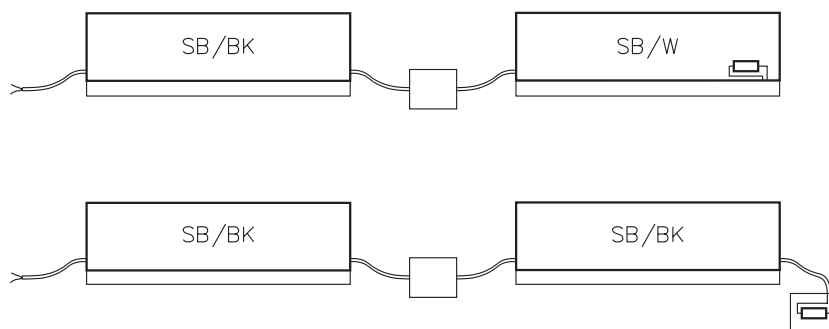

- Combinations:
- connection of several sensors
  - connection to Safe Edges and Safety Mats possible
  - only one control unit necessary

Model with external resistor, thus avoiding variety in type

**Cable connection (standard)**

- Cable: LiYY Ø 5 mm; 2x 0.25 mm<sup>2</sup> Cu
- length of cable: 2 m  
customized lengths possible
- cable ends without plug/socket connection  
option: cable ends can be supplied with plug/socket connection

Subject to technical modifications.

**4-wire-connection system  
(without monitoring resistor)**

**Safety Bumpers 3.2.2  
Product Range**

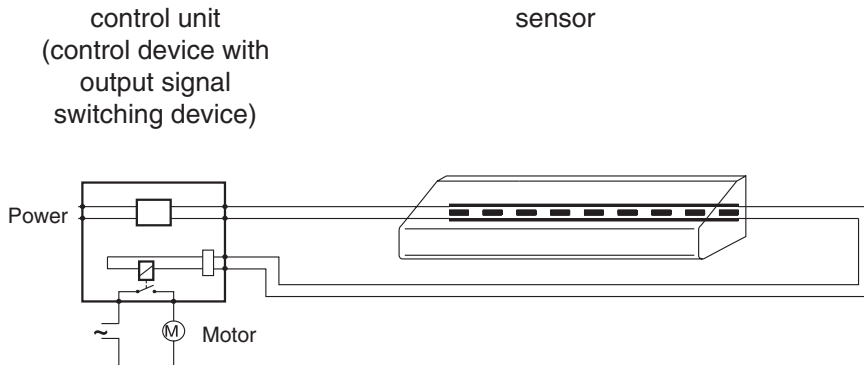

The Safety Bumper comprises sensor control device and output signal switching device. The signal processing and the output signal switching device are combined in the control unit.

**Type**

SB/BK through sensor with cables on both ends

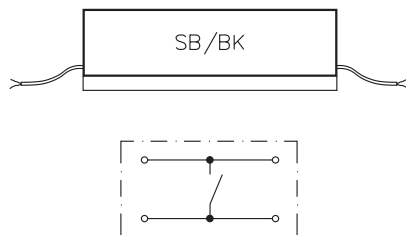

For your safety:  
The sensor and the connecting cable are constantly monitored for function. The monitoring resistor is not required due to signal transmission feedback

**Combination of sensors**

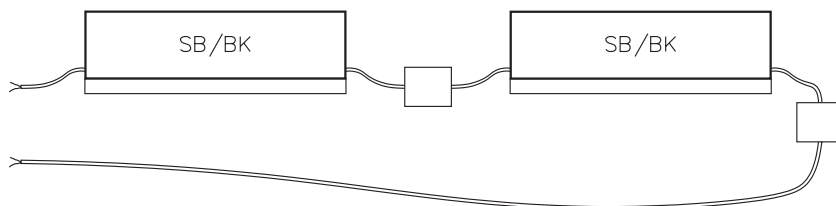

Combinations:  
- connection of several sensors  
- connection to Safe Edges and Safety Mats possible  
- only one control unit necessary

**Cable connection (standard)**

- cable: LiYY Ø 5 mm; 2x 0.25 mm<sup>2</sup> Cu
- length of cable: 2 m  
customized lengths possible
- cable ends without plug/socket connection  
option: cable ends can be supplied with plug/socket connection

**Note:**  
The 4-wire-connection system can only be applied using the control unit SG-SUE 41X4 NA.

Subject to technical modifications.

## Micro switch system (Break contact principle)

The Safety Bumper comprises only the sensor.  
The sensor can be connected either by means of a follow-up safety system  
or directly into the machine control system.

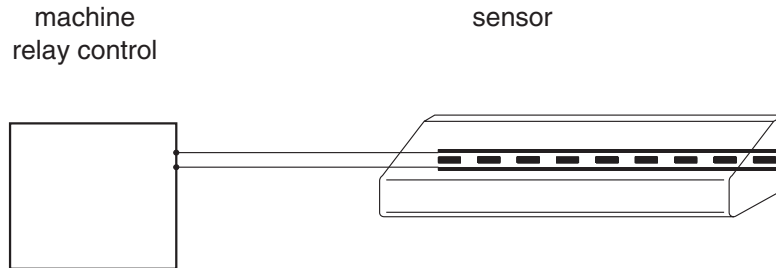

**Prerequisite:** The follow-up system  
must be in accordance with  
category 3 as per EN 954-1.

## Type

SB/Micro with integrated break contact principle

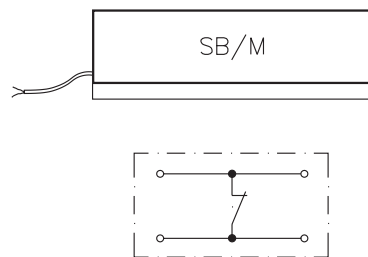

For your safety:  
The break contact principle  
monitors the system for a break in  
connection.  
The switch contacts are force  
guided.

## Combination of sensors

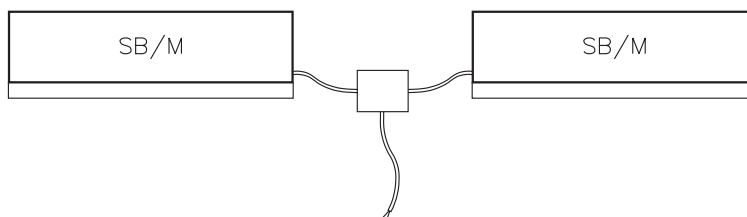

Combinations:  
- connection of several sensors  
- no control unit needed

## Cable connection (standard)

- cable: 4 GKWG-AX 1x 1.5 mm<sup>2</sup>
- length of cable: 2 m  
customized lengths possible
- cable ends without plug/socket connection

Subject to technical modifications.

## Standard System

## Safety Bumpers 3.3.1 Product Range

### Lengths available

The sensors can be supplied in lengths ranging from 100 to 4,000 mm. Special designs are available on enquiry.

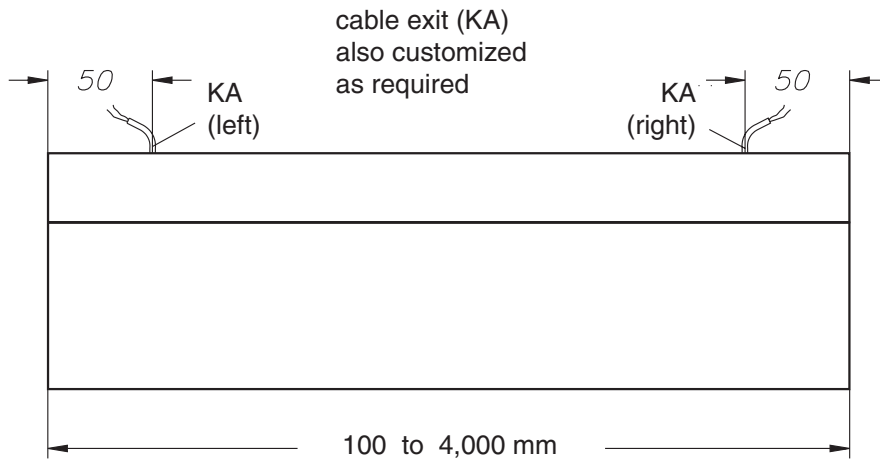

### Forms available

Standard sensors are available in 2 forms:

- Form A parallel form at Y = 40
- Form B cone shaped form at Y = 100; 150; 200

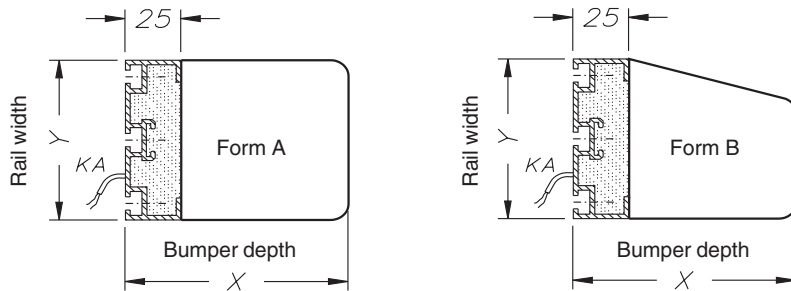

### Design lay-out / Mounting

All-purpose mounting with M 6 screws or nuts in continuous grooves in the C-rail.

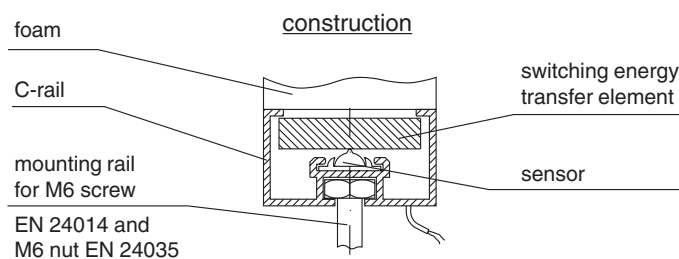

Subject to technical modifications.

## Standard System

### Colour

- deep black (similar to RAL 9005) or
- deep black with yellow stripes (similar to RAL 1021)

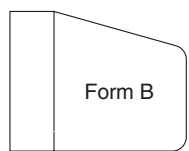
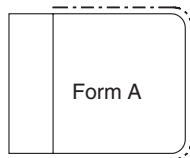
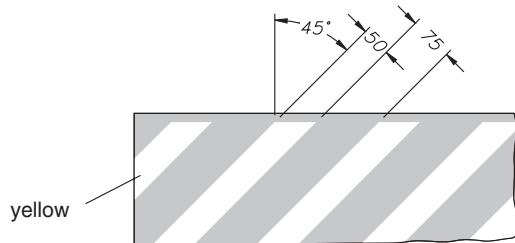

## Safety Bumpers 3.4.1 Product Range

The yellow stripes are applied to the area indicated by the chain-dotted line.

### Skin

- environmental-friendly PUR-skin with good mechanical properties
- protection class IP 65

### Chemical resistance

The following resistances are only given (at a room temperature of 23 °C) on condition that the bumper-skin is undamaged and intact.

Chemical Resistance	Skin
Acetone	±
Formic acid	-
Ammonia	+
ASTM-Oil No.1/ 2/ 3	+
Petroleum	±
Brake fluid	-
Diesel oil	+
Ethyl acetate	-
Isopropyl alcohol	+
Methanol	+
Hydrochloric acid 10 %	+
Hydrosulfuric acid 50 %	±
Spirit (ethyl alcohol)	+
Carbon tetrachloride	±
Rolling oil	+
Water	+
Hydrogen peroxide 10%	+
Household and sanitary cleaning agents	+

Key to symbols:  
+ = resistant  
± = limited resistance  
- = not resistant

The data given are results of tests which were done in our laboratory to the best of our knowledge and belief. We cannot accept any obligations being deduced from them. You must always test the suitability of our products for your special application purpose under practical conditions.

Subject to technical modifications.

**Standard System**

**Dimensions of aluminium mounting rail**

**Safety Bumpers 3.5.1  
Product Range**

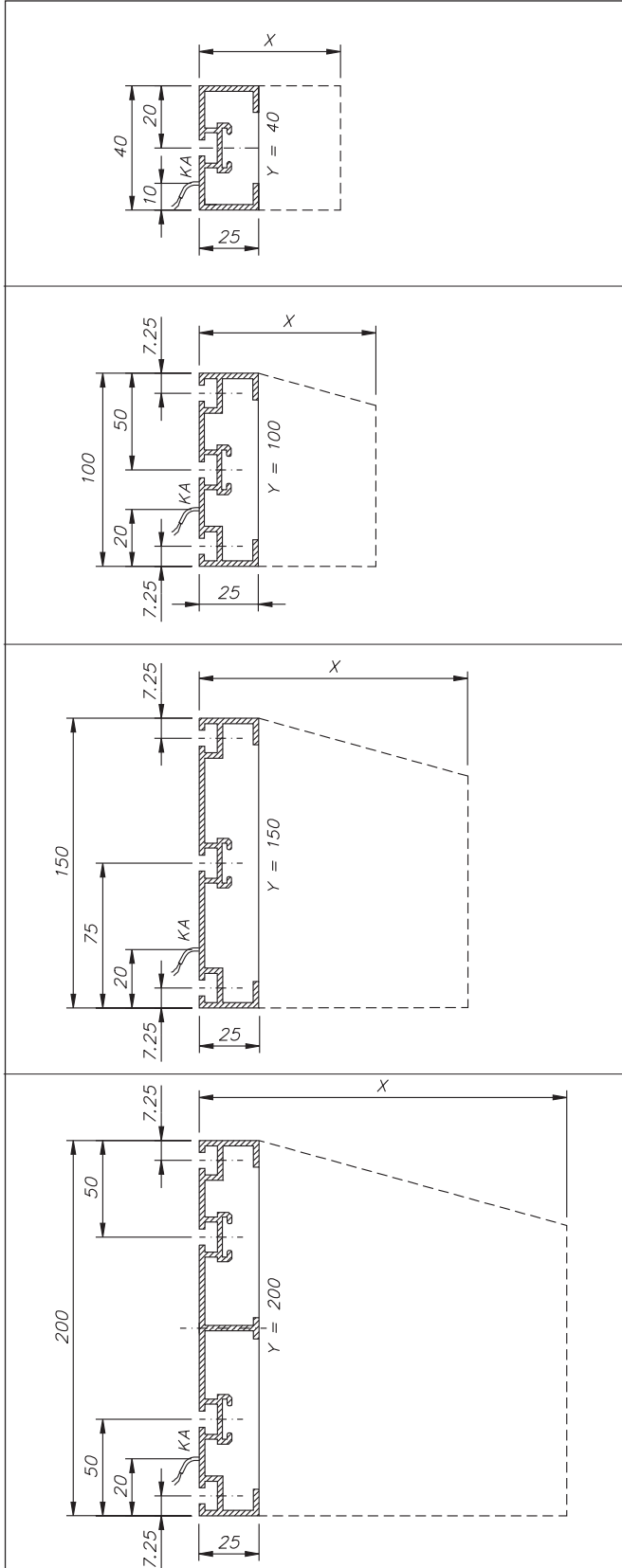

Form: **A**  
Rail width: **Y = 40**  
  
Bumper depth available: **X = 60 to 150**

Form: **B**  
Rail width: **Y = 100**  
  
Bumper depth available: **X = 60 to 200**

Form: **B**  
Rail width: **Y = 150**  
  
Bumper depth available: **X = 60 to 300**

Form: **B**  
Rail width: **Y = 200**  
  
Bumper depth available: **X = 60 to 500**

Subject to technical modifications.

## Standard System

### Technical Details

Form	Y	X	Actuating force	Reaction distance	Total deformation up to 250 N
			$F_G$ [N]	$S_B$ [mm]	$S_G$ [mm]
A	40	120	70	20	80
A	40	150	70	20	100
B	100	100	70	20	50
B	100	200	70	20	80
B	150	250	70	20	100
B	150	300	80	30	120
B	200	350	80	30	120
B	200	450	80	40	150

### Example:

Chosen Bumper:  
Form B; Y=150, X=300  
The contact is triggered at a reaction distance of 30 mm. 90 mm braking distance now remains (at a limit force of 250 N) until the AGV comes to a halt.

mm tolerances:  $\pm 10$  mm  
N tolerances:  $\pm 10$  N  
Test piece:  $\varnothing 80$  mm  
Test speed: 100 mm/s

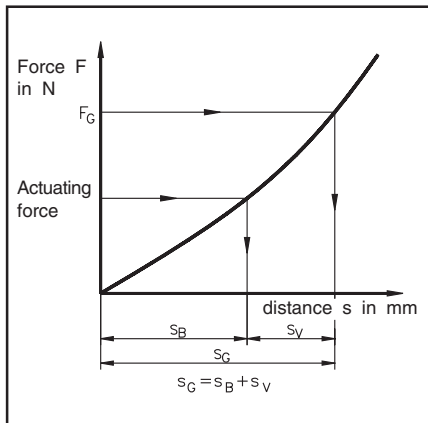

The force  $F_G$  represents a limit force up to which a sensor deforms and/or up to which it may continue to be moved.

In this connection it is assumed that no danger will arise for humans while this force is being applied.

The suggested standard value for an adult is  $F_G = 250$  N.

Formula for calculating the total deformation distance:

$$S_V [\text{mm}] = \text{overtravel}$$

$$S_G = S_B + S_V$$

Subject to technical modifications.

## Customized designs

## Safety Bumpers 3.7.1 Product Range

### Types

The Safety Bumpers can be supplied in various shapes and sizes for special applications.

- Forms: U-shaped, L-shaped, ...  
Surface: - various skins and colours (single colour, striped, ...)  
- protective coverings for high mechanical loads  
- heat resistant casings

Special solutions for use in hazardous locations possible.  
Customized mounting rail can be accommodated.

### Practical examples

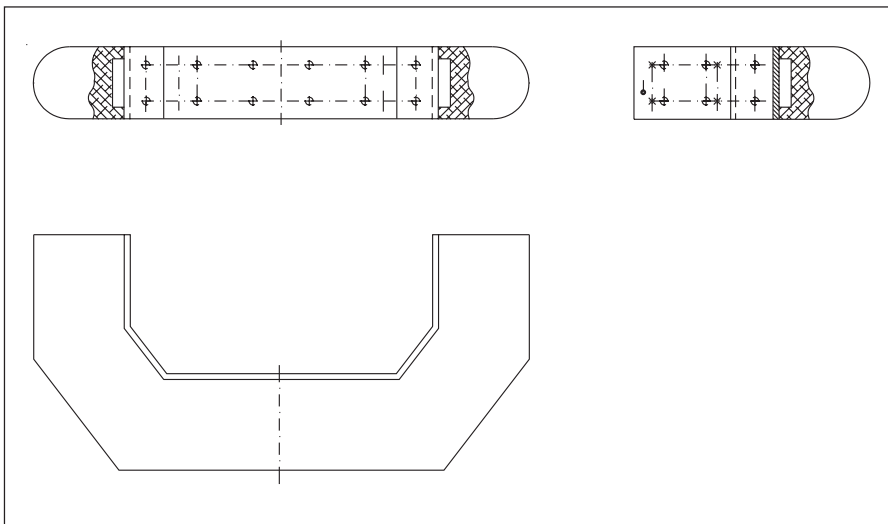

U-shape

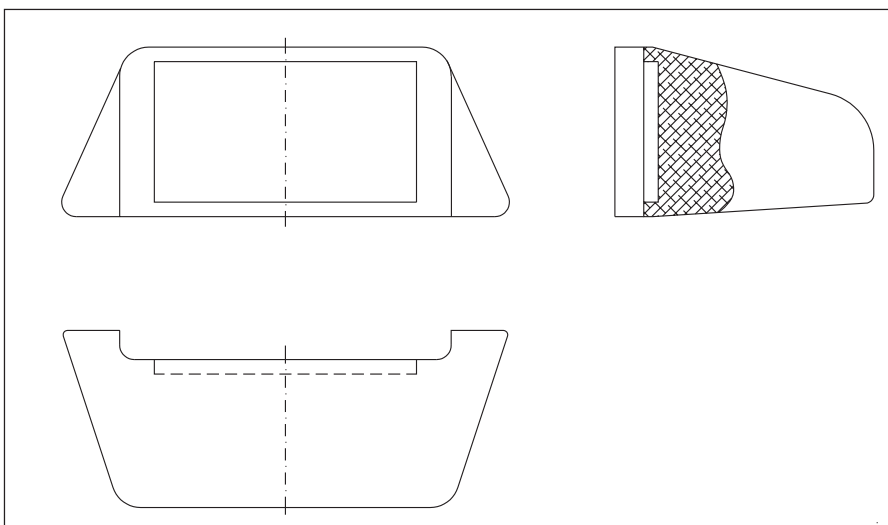

Trapezium-shape

### Special designs

If you need special shapes or special monitoring devices, get in touch with Mayser's project engineers directly.

Mayser Safety System  
We make progress safe!

Subject to technical modifications.

## Data sheet

## Safety Bumpers 3.9.1 Product Range

Safety Bumpers comprising sensors SB/W and SB/BK  
with al-mounting rail and control unit SG-EFS 1X4 ZK2/1  
Sensor dimensions: 1000 x 150 x 210 mm \*)

- |  |   |
|--|---|
| 1. Protection class sensor   | IP 65<br>IP 54 *)   |
| 2. Switching operations sensor   | > 10 <sup>5</sup><br>> 10 <sup>4</sup> *)   |
| 3. Switching times   |   |
| 3.1 Response time  | 22 ms   |
| Test speed   | 100 mm/s  |
| 3.2 Control command reset  | manual or automatic   |
| 4. Actuating force, deformation distance, Safety Bumper switching area |   |
| Testing basis: GS-BE-17  |   |
| Test piece   | Ø 80 mm      45 x 400 mm  |
| 4.1 Actuating force  | < 150 N      < 600 N  |
| 4.2 Deformation distances $s_v$<br>at 100 mm/s                         | 96 mm *)  |
| 4.3 Sensitive switching area WB  | 90° *)  |
| 5. Behaviour in fault instance   | One-fault-safety *)   |
| Category as per EN 954-1   | 3   |
| 6. Operating and environmental conditions                              |   |
| 6.1 Ambient temperature  |   |
| Sensor   | - 20 °C to + 55 °C *)   |
| 7. Operation –Maintenance  |   |
| 7.1 Maintenance  | The sensor is maintenance free.   |
| 7.2 Monitoring   | The control unit aids monitoring  |
| 7.3 Expert inspection<br>(once per year)<br>as per ZH 1/494            | •Both LEDs must light when the sensor is not activated.<br>•Both relays deenergize when the sensor is activated; both LEDs go out.<br>•This test must be undertaken to various parts of the sensor. |
| 8. Chemical resistance   | The sensor is resistant to customary chemical influences such as diluted acids, alkaline solutions and alcohol for an exposure duration of 24 hours.  |
| 9. Bumper Repair Kit<br>(accessories)                                  | Damages to the foam body can lead to functional impairment. The damage can be repaired using the Bumper Repair Kit.   |

All given data marked with \*) are verified by EEC-type-examination certificates.