

Linear Guideways

RG Series

2-4 RG Series – High Rigidity Roller Type Linear Guideway

2-4-1 Advantages and features

The new RG series from Hiwin features a roller as the rolling element instead of steel balls. The roller series offers super high rigidity and very high load capacities. The RG series is designed with a 45-degree angle of contact. Elastic deformation of the linear contact surface, during load, is greatly reduced thereby offering greater rigidity and higher load capacities in all 4 load directions. The RG series linear guideway offers high performance for high-precision manufacturing and achieving longer service life.

(1) Optimal design

FEM analysis was performed to determine the optimal structure of the block and the rail. The unique design of the circulation path allows the RG series linear guideway to offer smoother linear motion.

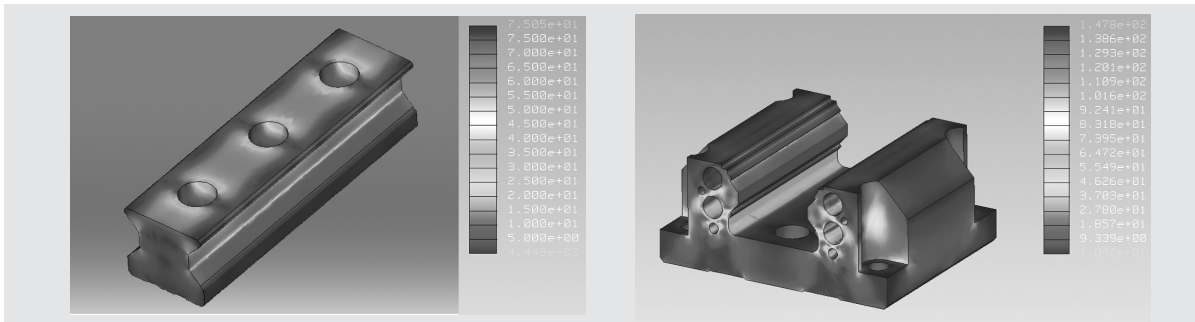

(2) Super high rigidity

The RG series is a type of linear guideway that uses rollers as the rolling elements. Rollers have a greater contact area than balls so that the roller guideway features higher load capacity and greater rigidity. The figure shows the rigidity of a roller and a ball with equal volume.

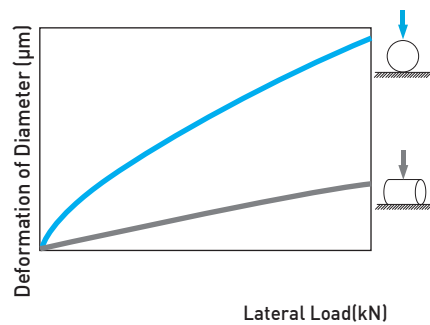

(3) Super high load capacity

With the four rows of rollers arranged at a contact angle of 45-degrees, the RG series linear guideway has equal load ratings in the radial, reverse radial and lateral directions. The RG series has a higher load capacity in a smaller size than conventional, ball-type linear guideways.

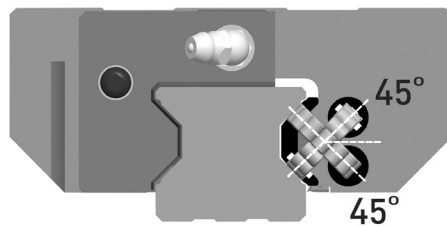

(4) Operating life increased

The basic dynamic load rating (100km rating) complies with ISO standard (ISO14728-1). The actual load will affect the nominal life of a linear guideway. Based on the selected basic dynamic rated load and the actual load, the nominal life can be calculated by using Eq.2.4. This life formula is different from that for conventional linear ball-type guideways.

$$L = \left(\frac{C}{P}\right)^{\frac{10}{3}} \cdot 100\text{km} = \left(\frac{C}{P}\right)^{\frac{10}{3}} \cdot 62\text{mile} \quad \dots\dots\dots \text{Eq. 2.4}$$

If the environmental factors are taken into consideration, the nominal life will be influenced greatly by the motion conditions, the hardness of the raceway, and the temperature of the linear guideway. The relationship between these factors is expressed in Eq.2.5.

$$L = \left(\frac{f_h \cdot f_t \cdot C}{f_w \cdot P}\right)^{\frac{10}{3}} \cdot 100\text{km} = \left(\frac{f_h \cdot f_t \cdot C}{f_w \cdot P}\right)^{\frac{10}{3}} \cdot 62\text{mile} \quad \dots\dots\dots \text{Eq. 2.5}$$

- L : Nominal life
- P : Calculated load
- C : Basic dynamic load rating
- f_h : Hardness factor
- f_t : Temperature factor
- f_w : Load factor

Where, the hardness factor, the temperature factor and the load factor are the same as a ball-type guideway. Compared with conventional linear ball-type guideways, the RG series linear guideway has a higher load capacity that allows it to achieve a longer service life.

(5) Durability test

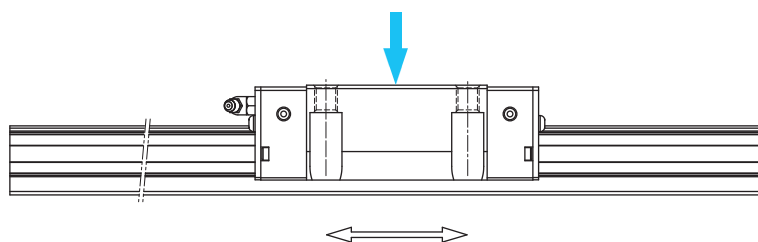

Model of the test system

Table 2.56

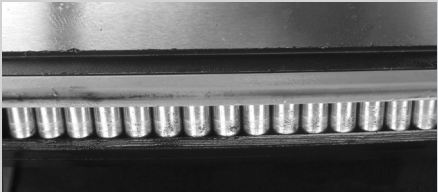
<p>Tested model 1: RGH35CA Preload: ZA class Max. Speed: 60m/min Acceleration: 1G Stroke: 0.55m Lubrication: grease held every 100km External: 15kN Traveling distance: 1135km</p>	<p>Test results: The nominal life of the model is 1000km. After the traveling distance, fatigue flaking did not appear on the surface of the raceway or rollers.</p> 
<p>Tested model 2: RGW35CC Preload: ZA class Max. Speed: 120m/min Acceleration: 1G Stroke: 2m Lubrication: oil feed rate: 0.3cm³/hr External load: 0kN Traveling distance: 15000km</p>	<p>Test results: Fatigue flaking did not appear on the surface of the raceway or rollers after a distance of (15000km).</p> 

Note: The data listed are from these samples.

Linear Guideways

RG Series

2-4-2 Construction of RG Series

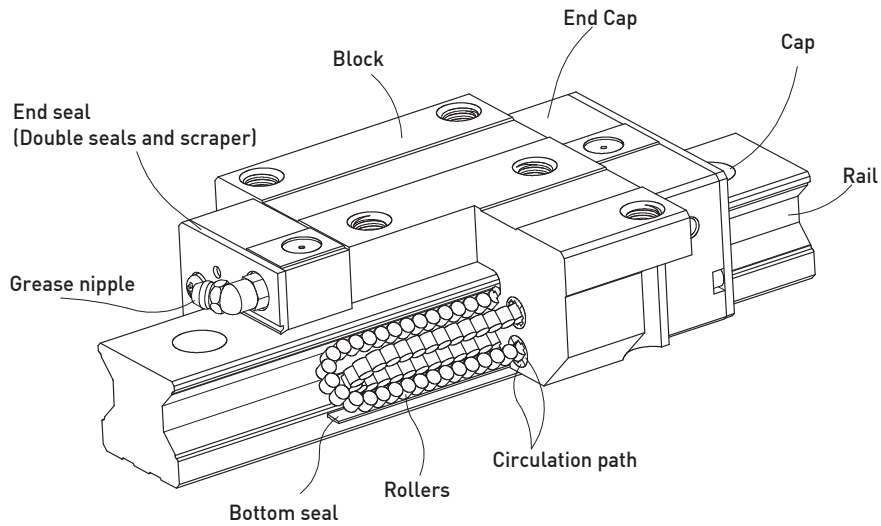

- Rolling circulation system: Block, Rail, End cap, Circulation path, rollers
- Lubrication system: Grease nipple and piping joint
- Dust protection system: End seal, Bottom seal, Cap, Double seals and Scraper

2-4-3 Model Number of RG series

In order to maintain H-class accuracy, the RG series linear guideway is available in only non-interchangeable types. Model numbers of the RG series contain the size, type, accuracy class, preload class, etc..

(1) Non-interchangeable type

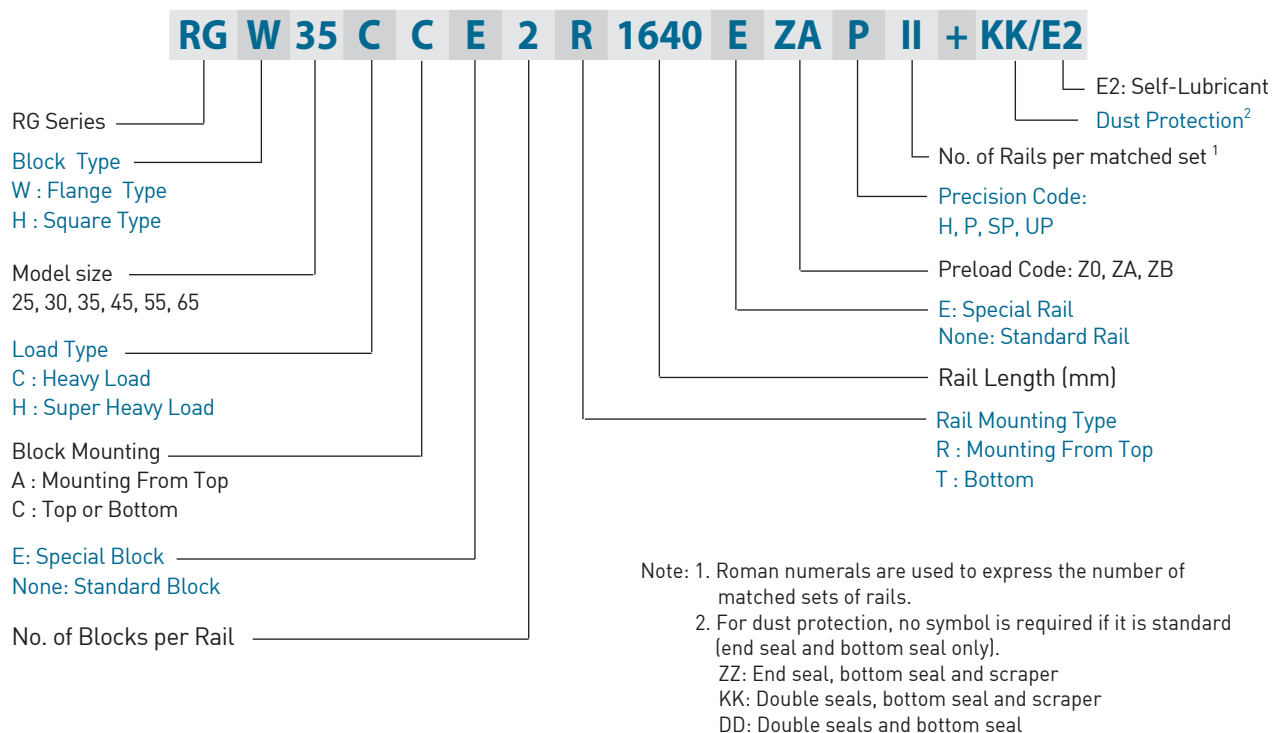

(2) Interchangeable type

○ Model Number of RG Block

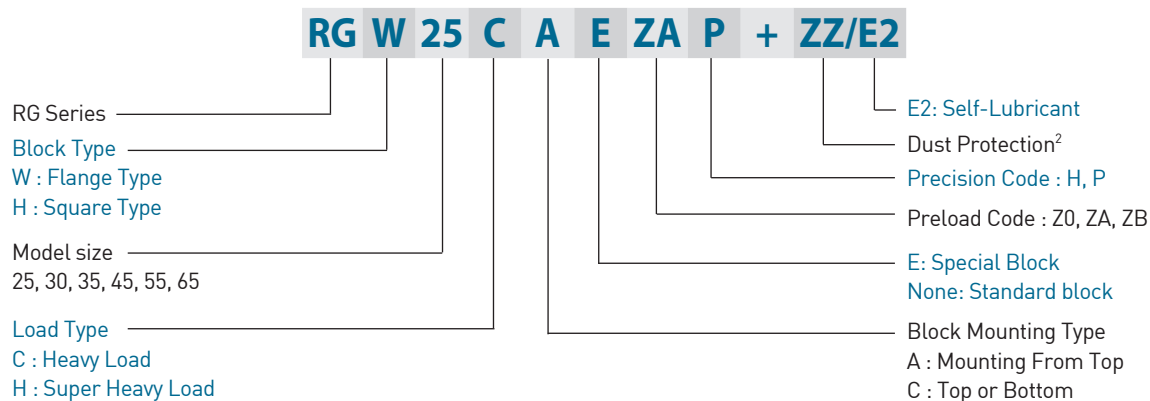

○ Model Number of RG Rail

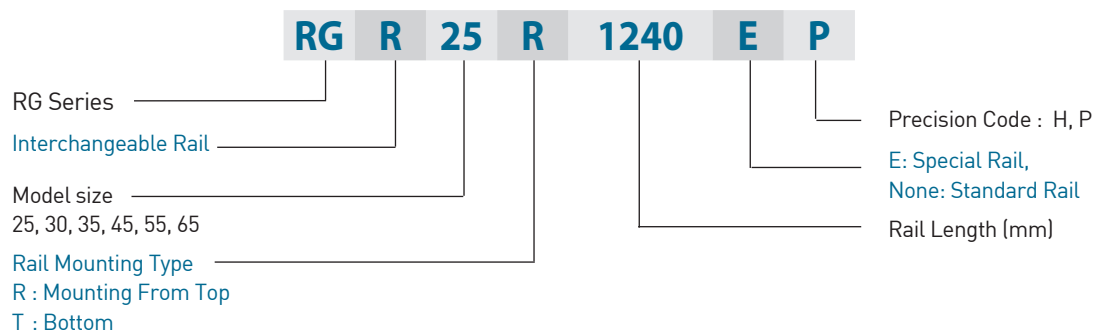

Linear Guideways

RG Series

2-4-4 Types

(1) Block types

HIWIN offers two types of guide blocks, flange and square type. Because of the low assembly height and large mounting surface, the flange type is excellent for heavy moment load applications.

Table 2.57 Block Types

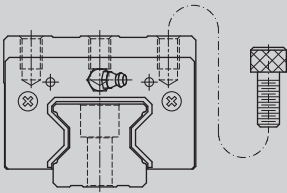
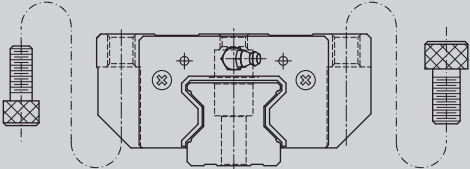
Type	Model	Shape	Height (mm)	Rail Length (mm)	Main Applications
Square	RGH-CA RGH-HA		40	100	<ul style="list-style-type: none"> ○ Automation Systems ○ Transportation equipment ○ CNC machining centers ○ Heavy duty cutting machines ○ CNC grinding machines ○ Injection molding machines ○ Plano millers ○ Devices requiring high rigidity ○ Devices requiring high load capacity ○ Electric discharge machines
			↓	↓	
90	4000				
Flange	RGW-CC RGW-HC		36	100	
			↓	↓	
90	4000				

(2) Rail types

In addition to the standard top mounting type, HIWIN also offers the bottom mounting type of rails.

Table 2.58 Rail Types

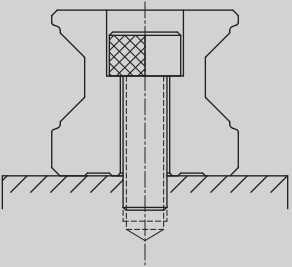
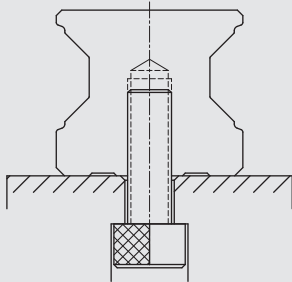
Mounting from Top	Mounting from Bottom
	

2-4-5 Accuracy Classes

The accuracy of the RG series can be classified into four classes: high (H), precision (P), super precision (SP) and ultra precision (UP). Customers may choose the class by referencing the accuracy requirements of the applied equipment.

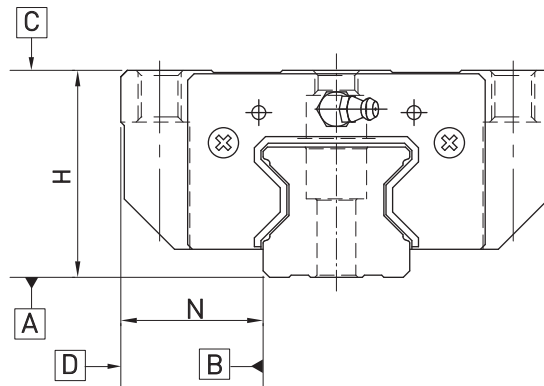

(1) Accuracy of non-interchangeable

Table 2.59 Accuracy Standards

Unit: mm

Item	RG - 25, 30, 35			
Accuracy Classes	High (H)	Precision (P)	Super Precision (SP)	Ultra Precision (UP)
Dimensional tolerance of height H	± 0.04	0 - 0.04	0 - 0.02	0 - 0.01
Dimensional tolerance of width N	± 0.04	0 - 0.04	0 - 0.02	0 - 0.01
Variation of height H	0.015	0.007	0.005	0.003
Variation of width N	0.015	0.007	0.005	0.003
Running parallelism of block surface C to surface A	See Table 2.65			
Running parallelism of block surface D to surface B	See Table 2.65			

Table 2.60 Accuracy Standards

Unit: mm

Item	RG - 45, 55			
Accuracy Classes	High (H)	Precision (P)	Super Precision (SP)	Ultra Precision (UP)
Dimensional tolerance of height H	± 0.05	0 - 0.05	0 - 0.03	0 - 0.02
Dimensional tolerance of width N	± 0.05	0 - 0.05	0 - 0.03	0 - 0.02
Variation of height H	0.015	0.007	0.005	0.003
Variation of width N	0.02	0.01	0.007	0.005
Running parallelism of block surface C to surface A	See Table 2.65			
Running parallelism of block surface D to surface B	See Table 2.65			

Table 2.61 Accuracy Standards

Unit: mm

Item	RG - 65			
Accuracy Classes	High (H)	Precision (P)	Super Precision (SP)	Ultra Precision (UP)
Dimensional tolerance of height H	± 0.07	0 - 0.07	0 - 0.05	0 - 0.03
Dimensional tolerance of width N	± 0.07	0 - 0.07	0 - 0.05	0 - 0.03
Variation of height H	0.02	0.01	0.007	0.005
Variation of width N	0.025	0.015	0.01	0.007
Running parallelism of block surface C to surface A	See Table 2.65			
Running parallelism of block surface D to surface B	See Table 2.65			

Linear Guideways

RG Series

(2) Accuracy of interchangeable

Table 2.62 Accuracy Standards

Unit: mm

Item	RG - 25, 30, 35	
Accuracy Classes	High (H)	Precision (P)
Dimensional tolerance of height H	± 0.04	± 0.02
Dimensional tolerance of width N	± 0.04	± 0.02
Variation of height H	0.015	0.007
Variation of width N	0.015	0.007
Running parallelism of block surface C to surface A	See Table 2.65	
Running parallelism of block surface D to surface B	See Table 2.65	

Table 2.63 Accuracy Standards

Unit: mm

Item	RG - 45, 55	
Accuracy Classes	High (H)	Precision (P)
Dimensional tolerance of height H	± 0.05	± 0.025
Dimensional tolerance of width N	± 0.05	± 0.025
Variation of height H	0.015	0.007
Variation of width N	0.02	0.01
Running parallelism of block surface C to surface A	See Table 2.65	
Running parallelism of block surface D to surface B	See Table 2.65	

Table 2.64 Accuracy Standards

Unit: mm

Item	RG - 65	
Accuracy Classes	High (H)	Precision (P)
Dimensional tolerance of height H	± 0.07	± 0.035
Dimensional tolerance of width N	± 0.07	± 0.035
Variation of height H	0.02	0.01
Variation of width N	0.025	0.015
Running parallelism of block surface C to surface A	See Table 2.65	
Running parallelism of block surface D to surface B	See Table 2.65	

(3) Accuracy of running parallelism

Table 2.65 Accuracy of Running Parallelism

Rail Length (mm)	Accuracy (µm)			
	H	P	SP	UP
~ 100	7	3	2	2
100 ~ 200	9	4	2	2
200 ~ 300	10	5	3	2
300 ~ 500	12	6	3	2
500 ~ 700	13	7	4	2
700 ~ 900	15	8	5	3
900 ~ 1,100	16	9	6	3
1,100 ~ 1,500	18	11	7	4
1,500 ~ 1,900	20	13	8	4
1,900 ~ 2,500	22	15	10	5
2,500 ~ 3,100	25	18	11	6
3,100 ~ 3,600	27	20	14	7
3,600 ~ 4,000	28	21	15	7

2-4-6 Preload

A preload can be applied to each guideway using oversized rollers. Generally, a linear motion guideway has negative clearance between the raceway and rollers to improve stiffness and maintain high precision. The RG series linear guideway offers three standard preloads for various applications and conditions.

Table 2.62

Class	Code	Preload	Condition
Light Preload	Z0	0.02C~0.04C	Certain load direction, low impact, low precision required
Medium Preload	ZA	0.07C~0.09C	High rigidity required, high precision required
Heavy Preload	ZB	0.12C~0.14C	Super high rigidity required, with vibration and impact

The figure shows the relationship between the rigidity, friction and nominal life. A preload no larger than ZA would be recommended for smaller model sizes to avoid over-preload affecting the life of the guideway.

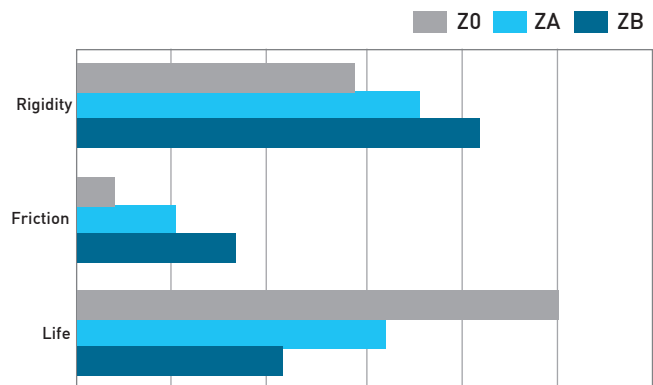

2-4-7 Lubrication

(1) Grease

- Grease nipple

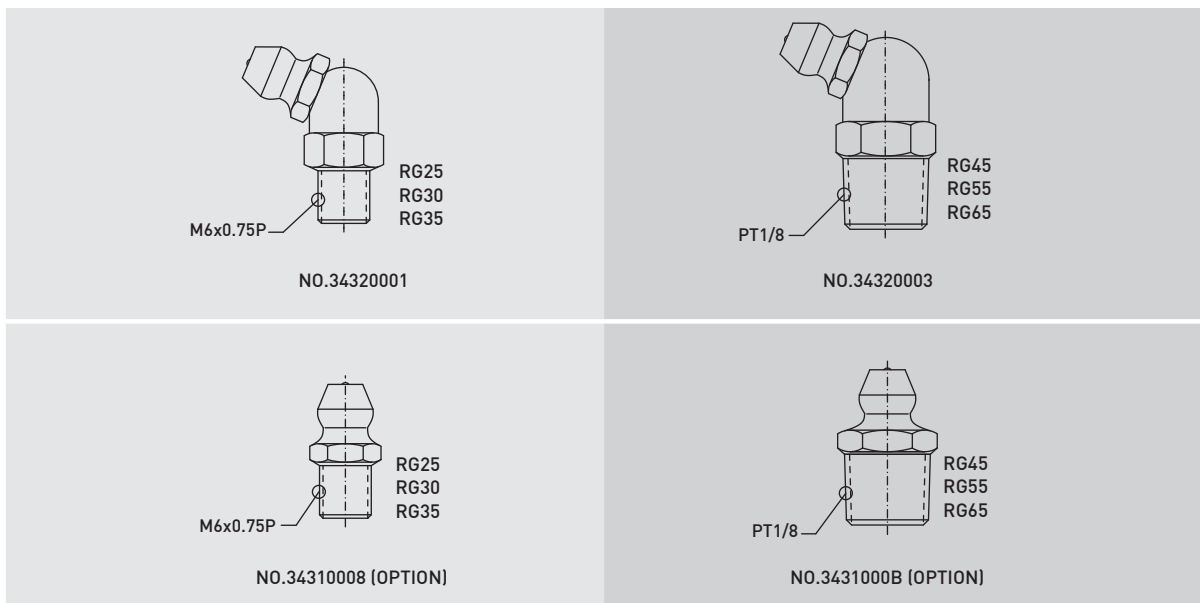

Linear Guideways

RG Series

○ Mounting location

The standard location of the grease fitting is at both ends of the block, but the nipple can be mounted in the side or the top of block. For lateral installation, we recommend that the nipple be mounted at the non-reference side, otherwise please contact us. It is possible to carry out the lubrication by using an oil-piping joint. The figure shows the locations of the grease fitting.

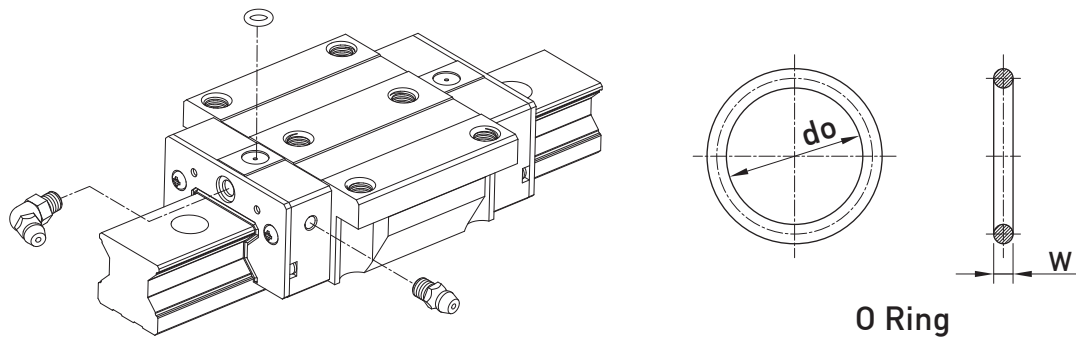
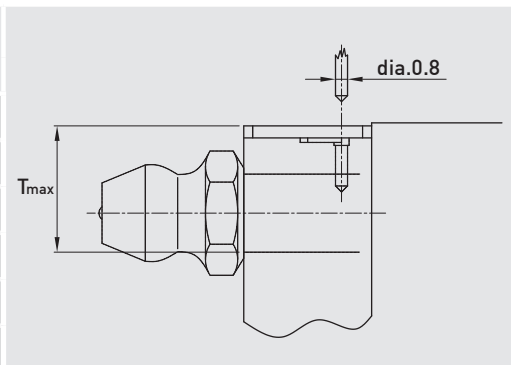

Table 2.67 O-Ring size and max. permissible depth for piercing

Size	O-Ring		Lube hole at top: max. permissible depth for piercing T_{max}
	do (mm)	W (mm)	
RG 25	7.5±0.15	1.5±0.15	5.8
RG 30	7.5±0.15	1.5±0.15	6.2
RG 35	7.5±0.15	1.5±0.15	8.65
RG 45	7.5±0.15	1.5±0.15	9.5
RG 55	7.5±0.15	1.5±0.15	11.6
RG 65	7.5±0.15	1.5±0.15	14.5



○ The oil amount for a block filled with grease

Table 2.68 The oil amount for a block filled with grease

Size	Medium Load [cm ³]	Heavy Load [cm ³]	Size	Medium Load [cm ³]	Heavy Load [cm ³]
RG 25	7	8	RG 45	19	23
RG 30	9	10	RG 55	28	35
HG 35	12	14	RG 65	52	63

○ Frequency of replenishment

Check the grease every 100 km, or every 3-6 months.

(2) Oil

The recommended viscosity of oil is about 32~150cSt. If you need to use oil-type lubrication, please inform us, then the block will not be prelubricated before shipment.

○ Types of oil piping joint

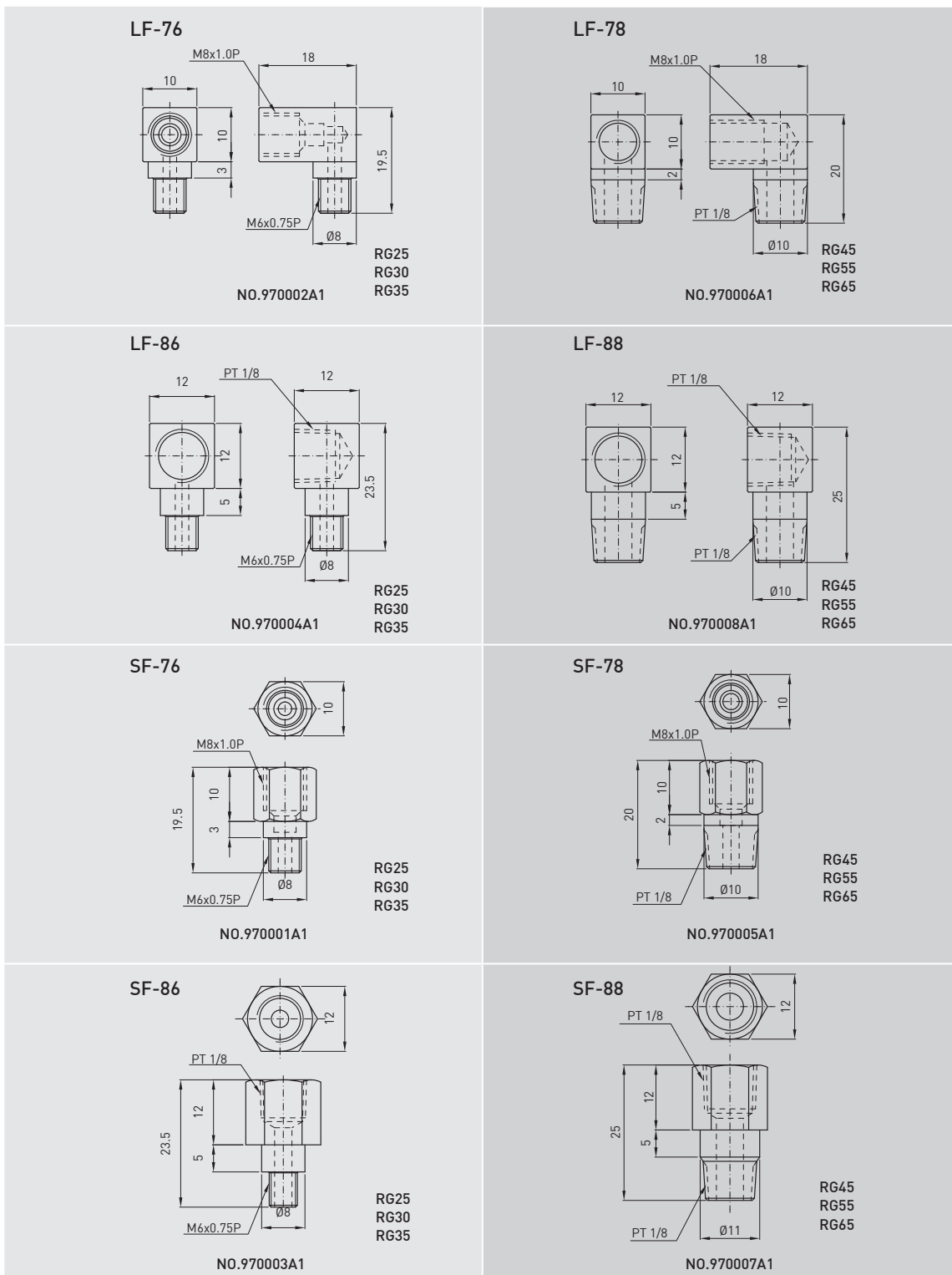

Linear Guideways

RG Series

Oil feeding rate

Table 2.69 oil feed rate

Size	feed rate (cm ³ /hr)	Size	feed rate (cm ³ /hr)
RG 25	0.167	RG 45	0.3
RG 30	0.2	RG 55	0.367
RG 35	0.23	RG 65	0.433

2-4-8 Dust Proof Accessories

(1) Codes of accessories

If the following accessories are needed, please add the code followed by the model number.

Table 2.70

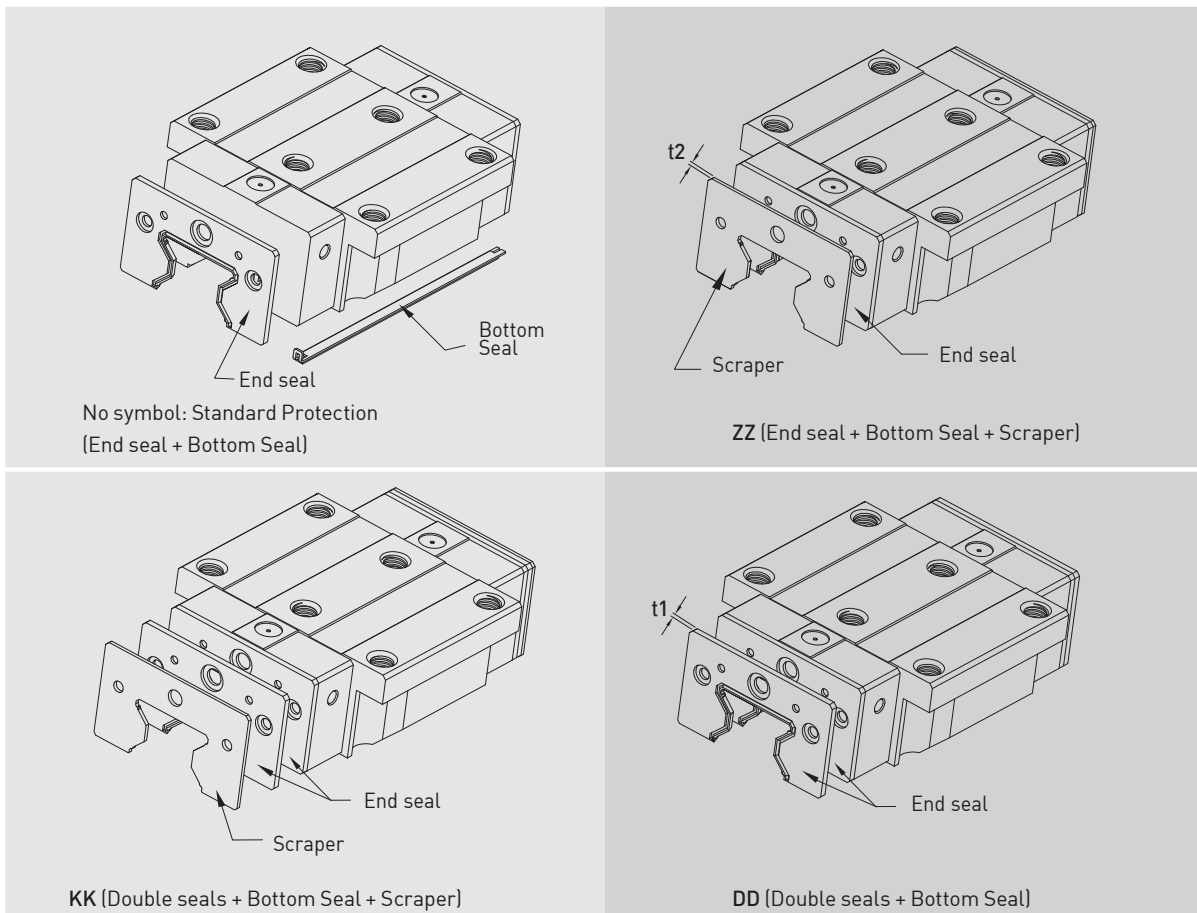

(2) End seal and bottom seal

To prevent life reduction caused by iron chips or dust entering the block.

(3) Double seals

Enhances the wiping effect, foreign matter can be completely wiped off.

Table 2.71 Dimensions of end seal

Size	Thickness (t1) (mm)	Size	Thickness (t1) (mm)
RG 25 ES	2.2	RG 45 ES	3.6
RG 30 ES	2.4	RG 55 ES	3.6
RG 35 ES	2.5	RG 65 ES	4.4

(4) Scraper

The scraper removes high-temperature iron chips and larger foreign objects.

Table 2.72 Dimensions of scraper

Size	Thickness (t2) (mm)	Size	Thickness (t2) (mm)
RG 25 SC	1.0	RG 45 SC	1.5
RG 30 SC	1.5	RG 55 SC	1.5
RG 35 SC	1.5	RG 65 SC	1.5

(5) Bolt caps for rail mounting holes

Caps are used to cover the mounting holes to prevent chips or other foreign objects from collecting in the holes. The caps will be enclosed in each rail package.



Table 2.73 Dimensions of Bolt Caps for Rail Mounting Holes

Rail size	Bolt size	Diameter(D) (mm)	Thickness(H) (mm)	Rail size	Bolt size	Diameter(D) (mm)	Thickness(H) (mm)
RGR25	M6	11.3	2.5	RGR45	M12	20.3	4.6
RGR30	M8	14.3	3.3	RGR55	M14	23.5	5.5
RGR35	M8	14.3	3.3	RGR65	M16	26.6	5.5

2-4-9 Friction

The maximum value of resistance per end seal are as shown in the table.

Table 2.74 Seal Resistance

Size	Resistance N (kgf)	Size	Resistance N (kgf)
RG25	2.74 (0.28)	RG45	4.21 (0.43)
RG30	3.31 (0.31)	RG55	5.09 (0.52)
RG35	3.53 (0.36)	RG65	6.66 (0.68)

Linear Guideways

RG Series

2-4-10 The Accuracy Tolerance of Mounting Surface

(1) The accuracy tolerance of rail-mounting surface

As long as the accuracy requirements of the mounting surfaces shown in the following tables are met, the high accuracy, high rigidity and long life of the RG series linear guideway will be maintained without any difficulty.

- The parallelism tolerance of reference surface (P)

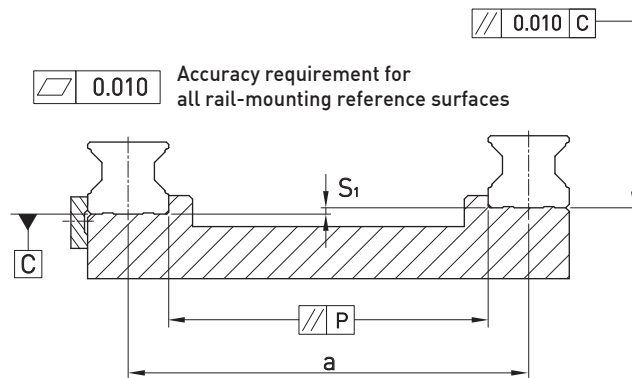

Table 2.75 Max. Parallelism Tolerance (P)

unit: μm

Size	Preload classes		
	Light Preload (Z0)	Medium Preload (ZA)	Heavy Preload (ZB)
RG25	9	7	5
RG30	11	8	6
RG35	14	10	7
RG45	17	13	9
RG55	21	14	11
RG65	27	18	14

- The accuracy tolerance of reference surface height (S_1)

$$S_1 = a \times K$$

S_1 : Max. tolerance of height

a : Distance between paired rails

K : Coefficient of tolerance of height

Table 2.76 Coefficient of tolerance of height

Size	Preload classes		
	Light Preload (Z0)	Medium Preload (ZA)	Heavy Preload (ZB)
K	2.2×10^{-4}	1.7×10^{-4}	1.2×10^{-4}

(2) The accuracy tolerance of block-mounting surface

- The tolerance of the height of reference surface when two or more pieces are used in parallel (S_2)

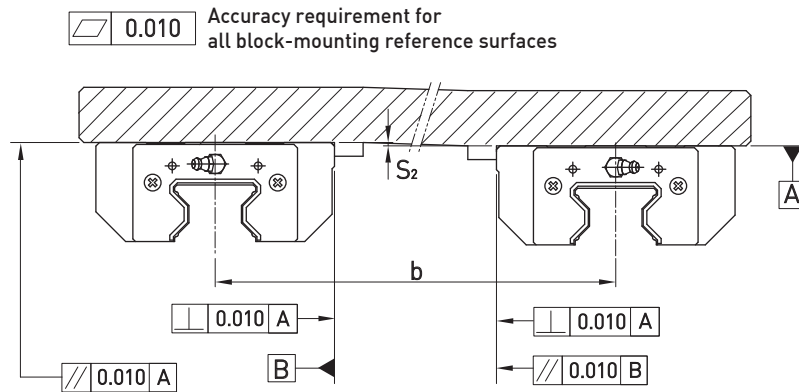

$$S_2 = b \times 4.2 \times 10^{-5}$$

S_2 : Max. tolerance of height
 b : Distance between paired blocks

- The tolerance of the height of reference surface when two or more pieces are used in parallel (S_3)

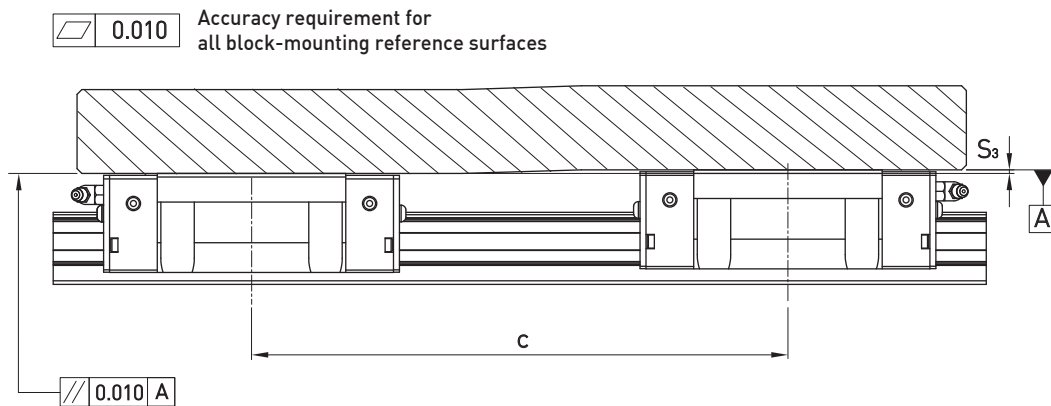

$$S_3 = c \times 4.2 \times 10^{-5}$$

S_3 : Max. tolerance of height
 c : Distance between paired blocks

Linear Guideways

RG Series

2-4-11 Cautions for Installation

(1) Shoulder heights and fillets

Improper shoulder heights and fillets of mounting surfaces will cause a deviation in accuracy and interference with the chamfered part of the rail or block.

By following the recommended shoulder heights and fillets, accuracy problems in installation can be eliminated.

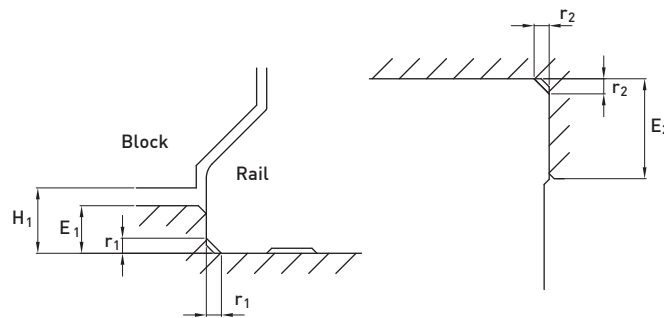

Table 2.77

Size	Max. radius of fillets r_1 (mm)	Max. radius of fillets r_2 (mm)	Shoulder height of the rail E_1 (mm)	Shoulder height of the block E_2 (mm)	Clearance under block H_1 (mm)
RG25	1.0	1.0	5	5	5.5
RG30	1.0	1.0	5	5	6
RG35	1.0	1.0	6	6	6.5
RG45	1.0	1.0	7	8	8
RG55	1.5	1.5	9	10	10
RG65	1.5	1.5	10	10	12

(2) Tightening Torque of Mounting Bolts

Improper tightening of mounting bolts will seriously influence the accuracy of a linear guideway. The following tightening torque for the different sizes of bolt is recommended.

Table 2.78

Size	Bolt size	Torque N-cm (kgf-cm)
RG25	M6×1P×20L	1373 (140)
RG30	M8×1.25P×25L	3041 (310)
RG35	M8×1.25P×25L	3041 (310)
RG45	M12×1.75P×35L	11772 (1200)
RG55	M14×2P×45L	15696 (1600)
RG65	M16×2P×50L	19620 (2000)

2-4-12 Standard and Maximum Lengths of Rail

HIWIN offers a number of standard rail lengths. Standard rail lengths feature end mounting hole placements set to predetermined values (E). For non-standard rail lengths, be sure to specify the E-value to be no greater than 1/2 the pitch (P) dimension. An E-value greater than this will result in unstable rail ends.

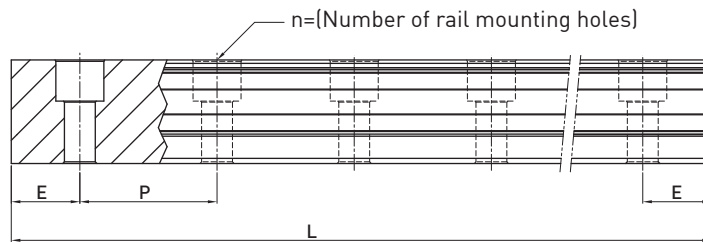

Table 2.79

unit: mm

Item	RGR25	RGR30	RGR35	RGR45	RGR55	RGR65
Standard Length L(n)	220 (7)	280 (7)	280 (7)	570 (11)	780 (13)	1,270 (17)
	280 (9)	440 (11)	440 (11)	885 (17)	1020 (17)	1,570 (21)
	340 (11)	600 (15)	600 (15)	1,200 (23)	1,260 (21)	2,020 (27)
	460 (15)	760 (19)	760 (19)	1,620 (31)	1,500 (25)	2,620 (35)
	640 (21)	1,000 (25)	1,000 (25)	2,040 (39)	1,980 (33)	-
	820 (27)	1,640 (41)	1,640 (41)	2,460 (47)	2,580 (43)	-
	1,000 (33)	2,040 (51)	2,040 (51)	2,985 (57)	2,940 (49)	-
	1,240 (41)	2,520 (63)	2,520 (63)	3,090 (59)	3,060 (51)	-
	1,600 (53)	3,000 (75)	3,000 (75)	-	-	-
Pitch (P)	30	40	40	52.5	60	75
Distance to End (E _s)	20	20	20	22.5	30	35
Max. Standard Length	4,000 (133)	3,960 (99)	3,960 (99)	3,930 (75)	3,900 (65)	3,970 (53)
Max. Length	4,000	4,000	4,000	4,000	4,000	4,000

Note : 1. Tolerance of E value for standard rail is 0.5~-0.5 mm. Tolerance of E value for jointed rail is 0~-0.3 mm.
 2. Maximum standard length means the max. rail length with standard E value on both sides.
 3. If different E value is needed, please contact HIWIN.

Linear Guideways

RG Series

2-4-13 Dimensions for RG series

(1) RGH-CA / RGH-HA

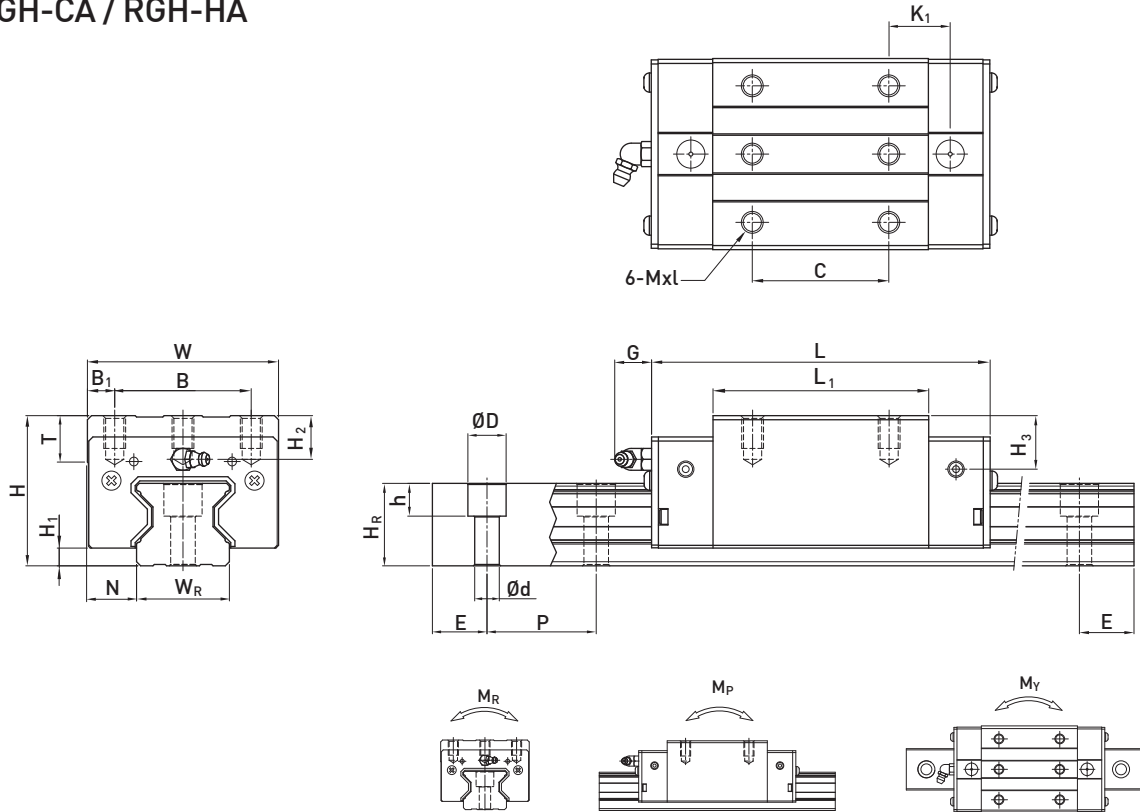

Model No.	Dimensions of Assembly (mm)			Dimensions of Block (mm)										Dimensions of Rail (mm)					Mounting Bolt for Rail (mm)	Basic Dynamic Load Rating C(kN)	Basic Static Load Rating C ₀ (kN)	Static Rated Moment			Weight					
	H	H ₁	N	W	B	B ₁	C	L ₁	L	K ₁	G	Mxl	T	H ₂	H ₃	W _R	H _R	D				h	d	P	E	M _R (kN-m)	M _P (kN-m)	M _Y (kN-m)	Block (kg)	Rail (kg/m)
	RGH 25CA	40	5.5	12.5	48	35	6.5	35	64.5	97.9	20.75	12	M6x8	9.5	10.2	10	23	23.6	11	9	7	30	20	M6x20	27.7	57.1	0.758	0.605	0.605	0.55
RGH 25HA							50	81	114.4	21.5													M6x20	33.9	73.4	0.975	0.991	0.991	0.7	
RGH 30CA	45	6	16	60	40	10	40	71	109.8	23.5	12	M8x10	9.5	9.5	10.3	28	28	14	12	9	40	20	M8x25	39.1	82.1	1.445	1.06	1.06	0.82	4.41
RGH 30HA							60	93	131.8	24.5																				
RGH 35CA	55	6.5	18	70	50	10	50	79	124	22.5	12	M8x12	12	16	19.6	34	30.2	14	12	9	40	20	M8x25	57.9	105.2	2.17	1.44	1.44	1.43	6.06
RGH 35HA							72	106.5	151.5	25.25																				
RGH 45CA	70	8	20.5	86	60	13	60	106	153.2	31	12.9	M10x17	16	20	24	45	38	20	17	14	52.5	22.5	M12x35	92.6	178.8	4.52	3.05	3.05	2.97	9.97
RGH 45HA							80	139.8	187	37.9																				
RGH 55CA	80	10	23.5	100	75	12.5	75	125.5	183.7	37.75	12.9	M12x18	17.5	22	27.5	53	44	23	20	16	60	30	M14x45	130.5	252	8.01	5.4	5.4	4.62	13.98
RGH 55HA							95	173.8	232	51.9																				
RGH 65CA	90	12	31.5	126	76	25	70	160	232	60.8	12.9	M16x20	25	15	15	63	53	26	22	18	75	35	M16x50	213	411.6	16.20	11.59	11.59	8.33	20.22
RGH 65HA							120	223	295	67.3																				

Note : 1 kgf = 9.81 N

Linear Guideways

RG Series

(3) Dimensions for RGR-T (Rail Mounting from Bottom)

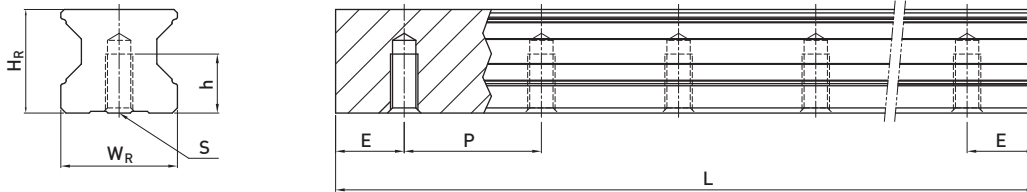

Model No.	Dimensions of Rail (mm)						Weight
	W_R	H_R	S	h	P	E	(kg/m)
RGR25T	23	23.6	M6×1P	12	30	20	3.36
RGR30T	28	28	M8×1.25P	15	40	20	4.82
RGR35T	34	30.2	M8×1.25P	17	40	20	6.48
RGR45T	45	38	M12×1.75P	24	52.5	22.5	10.83
RGR55T	53	44	M14×2P	24	60	30	15.15
RGR65T	63	53	M20×2.5P	30	75	35	21.24