

## 2-6 PG Type - Positioning Guideway

### (1) Construction of PG Type

PG is a Linear Guideway assembly integrated with a position measurement magnetic encoder.

### (2) HIWIN PG Features

1. The additional components are completely internal, thus saving installation space.
2. Maintains high rigidity as well as high accuracy.
3. Both sensor and magnetic strip are protected from externally harmful contaminants such as dust, iron chips, etc.
4. Non-contact measuring sensor can achieve longer life.
5. Can measure distances up to 30 m.
6. Can withstand humid, and high-temperature environments in oily, dusty, and high vibration applications.
7. High resolution
8. Easy to install

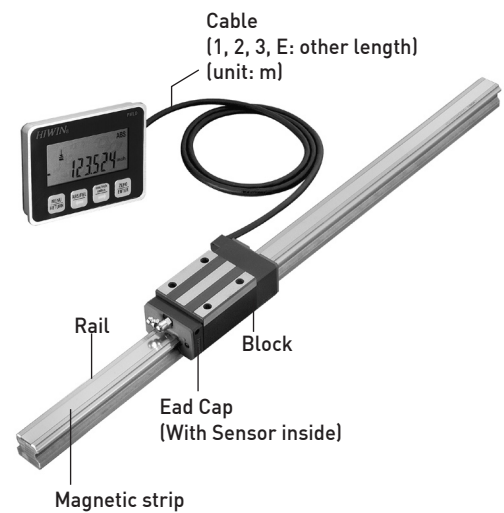

### 2-6-1 Model Number of PG Type

**PGH W 25 C A E 1/2 T 1600 E ZA P I/II/E2 + KK + 03 + □ □**

Positioning Guideway Series : PGH

Block Type :  
W : Flange Type  
H : Square Type

Model Size :  
20, 25, 30, 35, 45, 55

Load Type :  
C : Heavy Load  
H : Super Heavy Load

Block Mounting Type :  
A : From Top  
B : From Bottom  
C : Top or Bottom

E : Special Block  
None : Standard Block

Total No. of Blocks with Sensor for all Rails

No. of Blocks per Axis

Rail Mounting Type :  
R : From Top  
T : From Bottom

L D = Multi-function LCD display (Option)  
D P = Display (Option)  
1 2 = Signal Translator

Output Signal Type:  
1:5V input, TTL output  
2:24V input, O.C. output

Resolution:  
1=5μm  
2=10μm

Cable Length :  
01=1m; 02=2m  
03=3m; 10=10m

Dustproof : DD, ZZ, KK

E2 : Self Lubricant Block  
Blank: Standard Block

No. of Rails per Axis

No. of Rails with Magnetic Strip

Precision Code : C, H, P

Preload Code :  
Z0, ZA, ZB

E : Special Rail  
None : Standard Rail



Rail Length (mm)

# Linear Guideways

## PG Type

### 2-6-2 Technical Data of PG Type

Table 2.82

Specifications Item			
	Signal Translator	Display	Multi-function LCD Display
Measuring length	Max. 10M (option: Max. 30M)	Max. 10M (option: Max. 30M)	Max. 10M (option: Max. 30M)
Resolution (μm)	5/10	5	5
Accuracy (μm)	± (80+15×L), L: Scale length unit(m)	± (80+15×L), L: Scale length unit(m)	± (80+15×L), L: Scale length unit(m)
Repeatability (μm)	±10 μ / m	±10 μ / m	±10 μ / m
Max. velocity (m/sec)	1.2 (Acc. 1G)	3 (Acc. 2G)	3 (Acc. 2G)
Output pulse signals	A, B phase differential, 0.C	-	-
Max. output frequency (KHZ)	64/ 32 (at resolution: 5/10μm)	-	-
Power input	DC5V ±5% / 1A	DC5V ±5% / 1A	Commercial AA battery x 2
Battery life		-	1 year (when set at 1.5m/s)
Operating temperature(°C)	0 ~ 50	0 ~ 50	0 ~ 50
Storage temperature(°C)	-5 ~ 70	-5 ~ 70	-5 ~ 70
IP Class	Scale / Sensor: IP66, Display : IP43	Scale / Sensor: IP66, Display : IP43	Scale / Sensor: IP66, Display : IP43

### Signal Translator

► D-type 9 pin layout:

- Pin1 = 0V
- Pin2 = 5V/DC
- Pin3 = channel A
- Pin4 = channel B
- Pin7 = channel  $\bar{B}$
- Pin8 = channel  $\bar{A}$

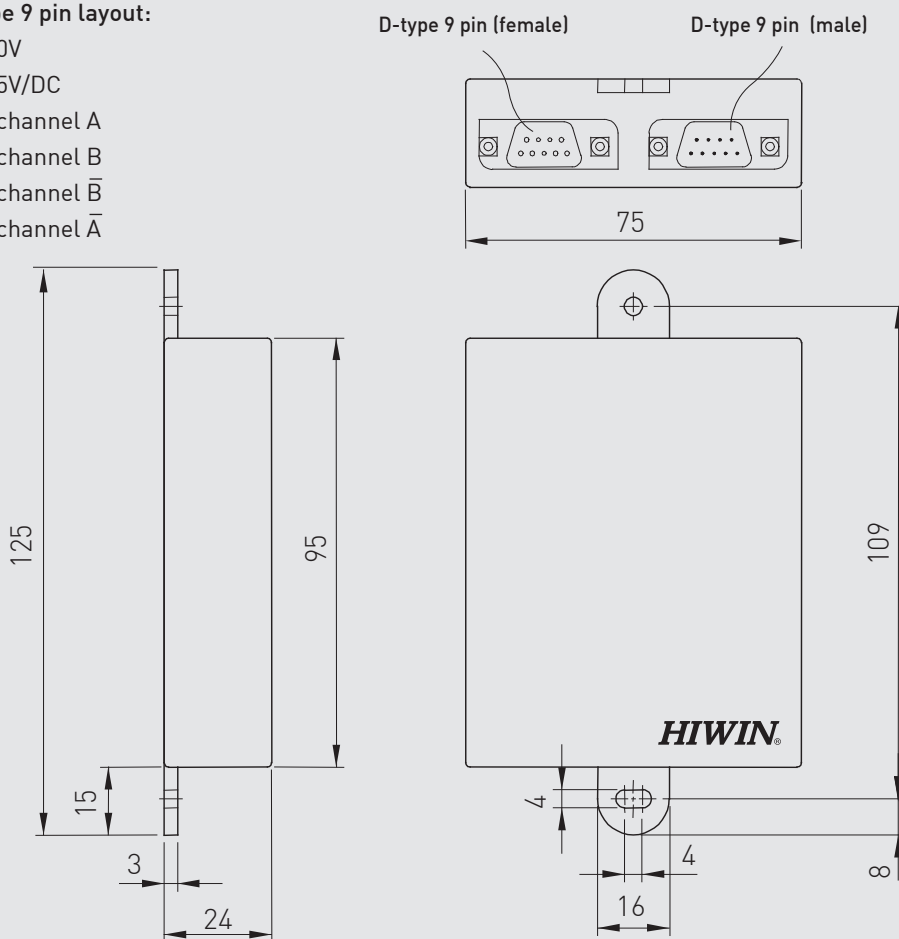

### Display

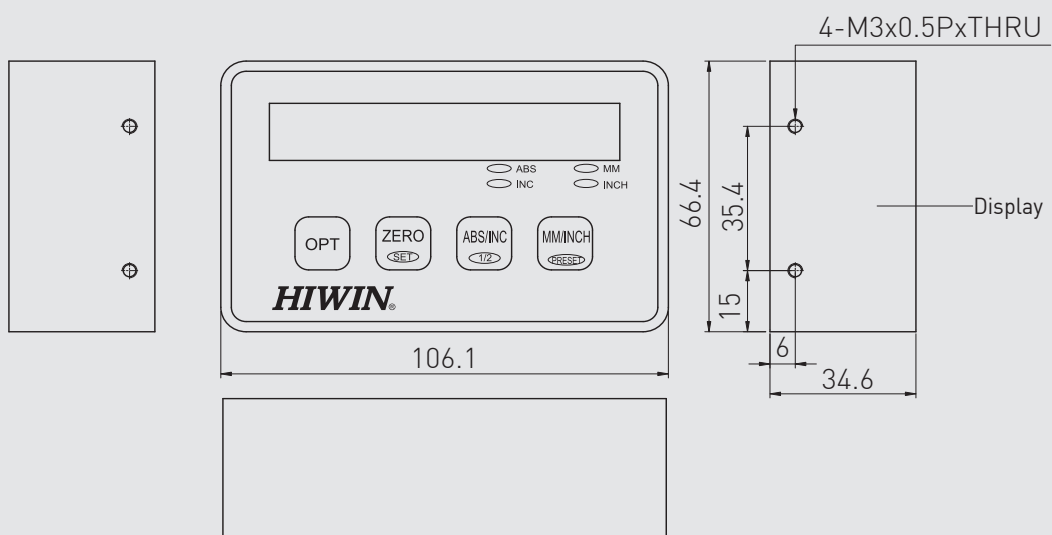

# Linear Guideways

## PG Type

### Multi-function LCD Display

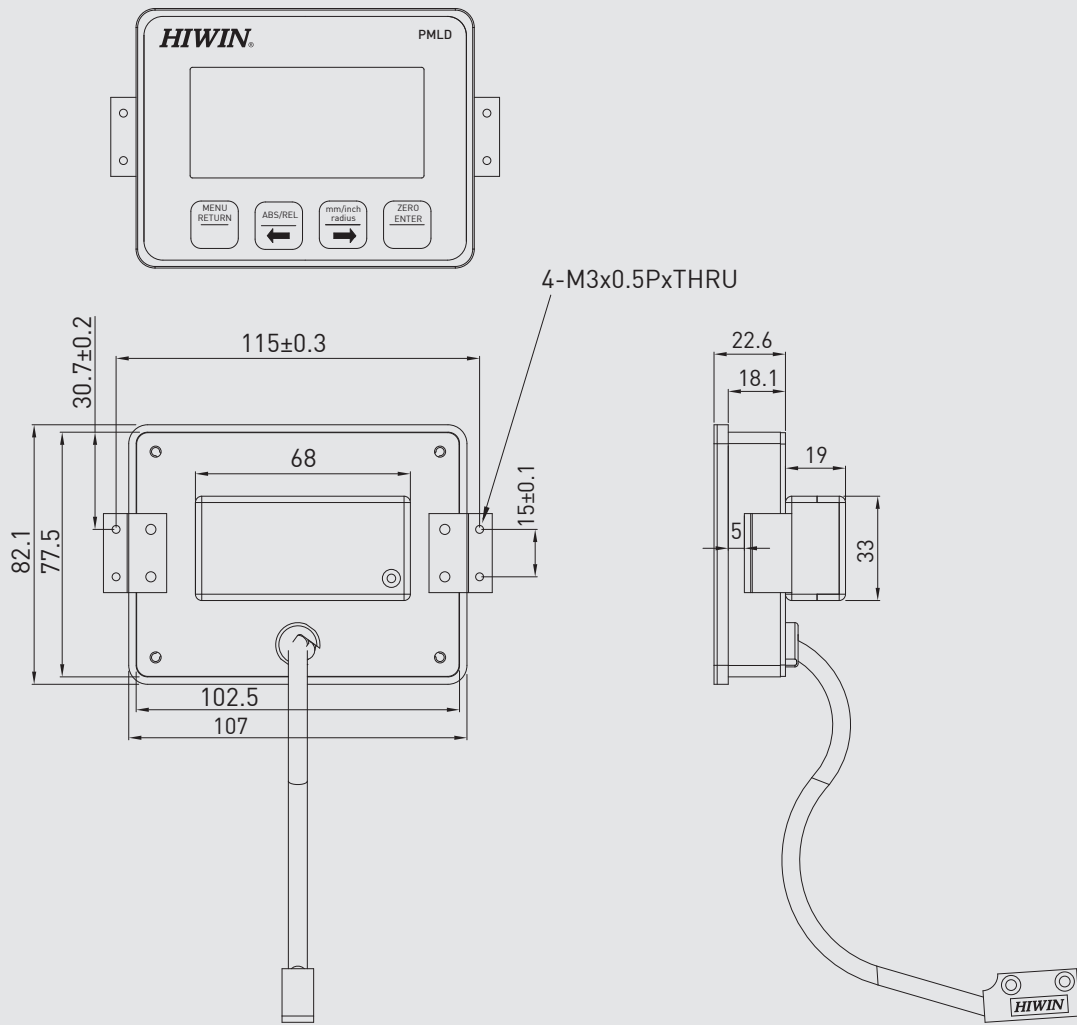

### 2-6-3 Accuracy Classes

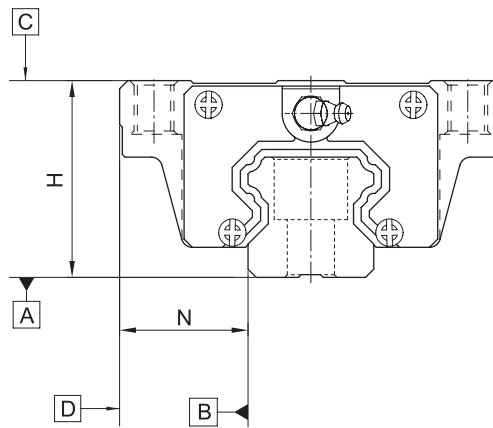
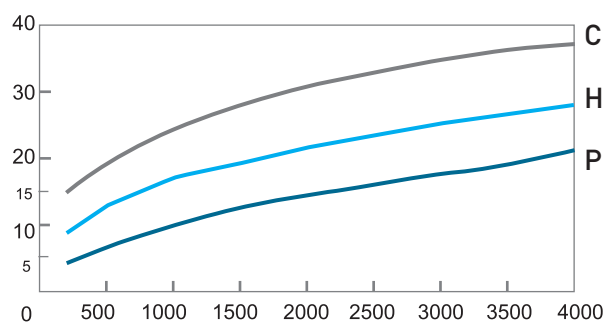

Table 2.83 For example: PGH 25, 30, 35

Unit: mm

Accuracy Classes	Normal (C)	High (H)	Precision (P)
Dimensional tolerance of height H	± 0.1	± 0.04	0 -0.04
Dimensional tolerance of width N	± 0.1	± 0.04	0 -0.04
Pair Variation of height H	0.02	0.015	0.007
Pair Variation of width N (Master Rail)	0.03	0.015	0.007
Running parallelism of block surface C to surface A	See chart below		
Running parallelism of block surface D to surface B	See chart below		

#### Running parallelism of the guideway



### 2-6-4 Preload

Table 2.84 PGH-series

Class	Code	Preload
Light Preload	Z0	0~0.02C
Medium Preload	ZA	0.05C~0.07C
Heavy Preload	ZB	0.10C~0.12C

Note: "C" in column preload means basic dynamic load rating.

# Linear Guideways

## PG Type

### 2-6-5 Dimensions for PG Series

#### (1) PGHH-CA / PGHH-HA

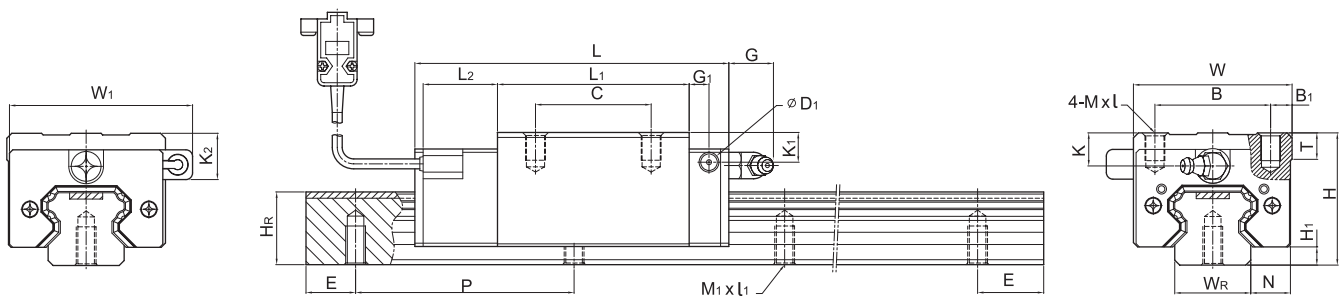

Model No.	Dimensions of Assembly (mm)				Dimensions of Block (mm)														Dimensions of Rail (mm)					Basic Dynamic Load Rating C (kN)	Basic Static Load Rating C <sub>0</sub> (kN)	Weight			
	H	H <sub>1</sub>	N	W	W <sub>1</sub>	B	B <sub>1</sub>	C	L	L <sub>1</sub>	L <sub>2</sub>	G	G <sub>1</sub>	D <sub>1</sub>	K	K <sub>1</sub>	K <sub>2</sub>	M x l	T	W <sub>R</sub>	H <sub>R</sub>	M <sub>1</sub> x l <sub>1</sub>	P			E	kg	kg/m	
																													Block
PGHH20CA	30	4.6	12	44	52	32	6	36	90.5	50.5	25	12	6	5	6	7	10	M5x6	8	20	17.5	17.5	M6x10	60	20	17.75	37.84	0.38	2.21
PGHH20HA								50	105.2	65.2																			
PGHH25CA	40	5.5	12.5	48	55.4	35	6.5	35	95	58	22.5	12	6	5	10	13	18	M6x8	8	23	22	M6x12	60	20	26.48	56.19	0.51	3.21	
PGHH25HA								50	116	78.6																			
PGHH30CA	45	6	16	60	67	40	10	40	110	70	23	12	6	5	9.5	13.8	19	M8x10	8.5	28	26	M8x15	80	20	38.74	83.06	0.88	4.47	
PIGHH30HA								60	133	93																			
PGHH35CA	55	7.5	18	70	77	50	10	50	123	80	23.4	12	7	5	16	19.6	23.5	M8x12	10.2	34	29	M8x17	80	20	49.52	102.87	1.45	6.30	
PGHH35HA								72	149	106																			
PGHH45CA	70	9.5	20.5	86	91	60	13	60	148	97	24.5	12.9	10	8.5	18.5	30.5	30.5	M10x17	16	45	38	M12x24	105	22.5	77.57	155.93	2.73	10.41	
PGHH45HA								80	180	129																			
PGHH55CA	80	13	23.5	100	106	75	12.5	75	173	118	26	12.9	11	8.5	22	29	28.5	M12x18	17.5	53	44	M14x25	120	30	114.44	227.81	4.17	15.08	
PGHH55HA								95	198	143																			

Note : 1 kgf = 9.81 N

(2) PGHW-CA / PGHW-HA

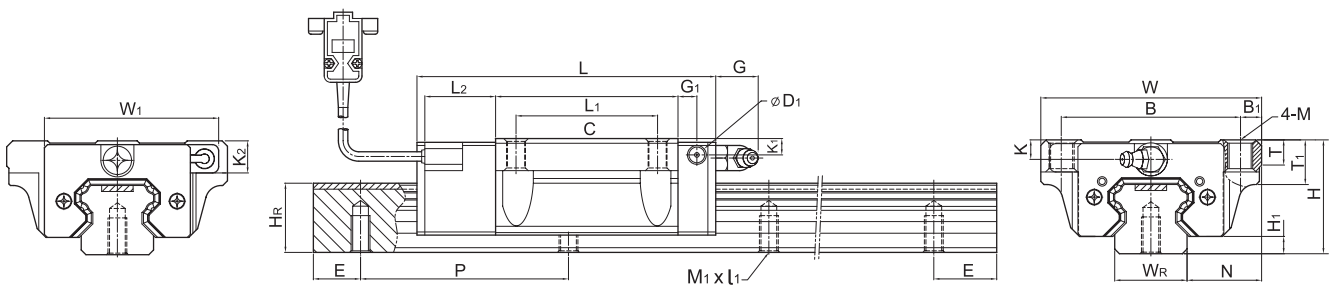

Model No.	Dimensions of Assembly (mm)									Dimensions of Block (mm)														Dimensions of Rail (mm)					Basic Dynamic Load Rating	Basic Static Load Rating	Weight	
	H	H <sub>1</sub>	N	W	W <sub>1</sub>	B	B <sub>1</sub>	C	L	L <sub>1</sub>	L <sub>2</sub>	G	G <sub>1</sub>	D <sub>1</sub>	M	K	K <sub>1</sub>	K <sub>2</sub>	T	T <sub>1</sub>	W <sub>R</sub>	H <sub>R</sub>	M <sub>1</sub> x <sub>l<sub>1</sub></sub>	P	E	C (kN)	C <sub>0</sub> (kN)	Block			Rail	
	kg	kg/m																														
PGHW20CA	30	4.6	21.5	63	52	53	5	40	90.5	50.5																	17.75	37.84	0.40	2.21		
PGHW20HA									105.2	65.2	25	12	6	5	M6	6	7	10	8	10	20	17.5	M6x10	60	20	21.18	48.84	0.52				
PGHW25CA	36	5.5	23.5	70	55.4	57	6.5	45	95	58																26.48	56.19	0.59	3.21			
PGHW25HA									116	78.6	22.5	12	6	5	M8	6	9	14	8	14	23	22	M6x12	60	20	32.75	76.00	0.80				
PGHW30CA	42	6	31	90	67	72	9	52	110	70																38.74	83.06	1.09	4.47			
PGHW30HA									133	93	23	12	6	5	M10	6.5	10.8	16	8.5	16	28	26	M8x15	80	20	47.27	110.13	1.44				
PGHW35CA	48	7.5	33	100	77	82	9	62	123	80																49.52	102.87	1.56	6.30			
PGHW35HA									149	106	23.4	12	7	5	M10	9	12.6	16.5	10.1	18	34	29	M8x17	80	20	60.21	136.31	2.06				
PGHW45CA	60	9.5	37.5	120	91	100	10	80	148	97																77.57	155.93	2.79	10.41			
PGHW45HA									180	129	24.5	12.9	10	8.5	M12	8.5	20	20	15.1	22	45	38	M12x24	105	22.5	94.54	207.12	3.69				
PGHW55CA	70	13	43.5	140	106	116	12	95	173	118																114.44	227.81	4.52	15.08			
PGHW55HA									198	143	26	12.9	11	8.5	M14	12	19	18.5	17.5	26.5	53	44	M14x25	120	30	139.35	301.26	5.96				

Note : 1 kgf = 9.81 N