

2-1 HG Series - Heavy Load Ball Type Linear Guideway

HG series linear guideways are designed with load capacity and rigidity higher than other similar products with circular-arc groove and structure optimization. It features equal load ratings in the radial, reverse radial and lateral directions, and self-aligning to absorb installation-error. Thus, HIWIN HG series linear guideways can achieve a long life with high speed, high accuracy and smooth linear motion.

2-1-1 Features of HG Series

(1) Self-aligning capability

By design, the circular-arc groove has contact points at 45 degrees. HG series can absorb most installation errors due to surface irregularities and provide smooth linear motion through the elastic deformation of rolling elements and the shift of contact points. Self-aligning capability, high accuracy and smooth operation can be obtained with an easy installation.

(2) Interchangeability

Because of precision dimensional control, the dimensional tolerance of HG series can be kept in a reasonable range, which means that any blocks and any rails in a specific series can be used together while maintaining dimensional tolerance. And a retainer is added to prevent the balls from falling out when the blocks are removed from the rail.

(3) High rigidity in all four directions

Because of the four-row design, the HG series linear guideway has equal load ratings in the radial, reverse radial and lateral directions. Furthermore, the circular-arc groove provides a wide-contact width between the balls and the groove raceway allowing large permissible loads and high rigidity.

2-1-2 Construction of HG Series

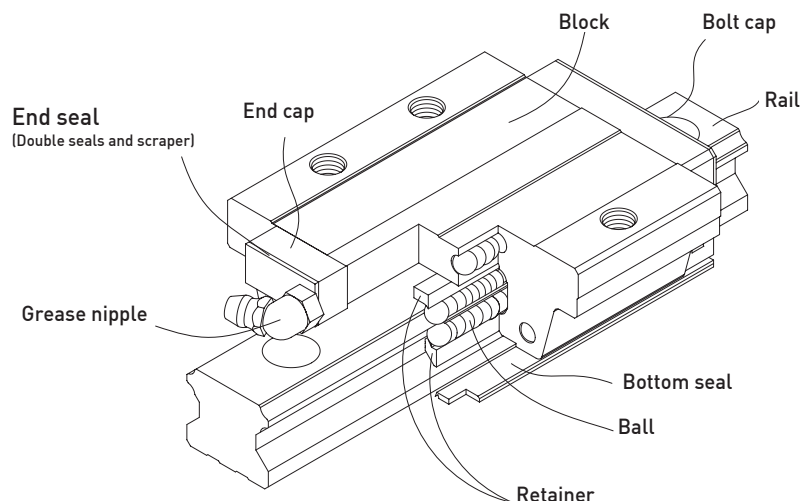

- Rolling circulation system: Block, Rail, End Cap and Retainer
- Lubrication system: Grease Nipple and Piping Joint
- Dust protection system: End seal, Bottom Seal, Bolt Cap, Double Seals and Scraper

2-1-3 Model Number of HG Series

HG series guideways can be classified into non-interchangeable and interchangeable types. The sizes are identical. The only difference between the two types is that the interchangeable type of blocks and rails can be freely exchanged, and their accuracy can reach up to P class. The model number of HG series contains the size, type, accuracy class, preload class, etc..

Linear Guideways

HG Series

(1) Non-interchangeable type

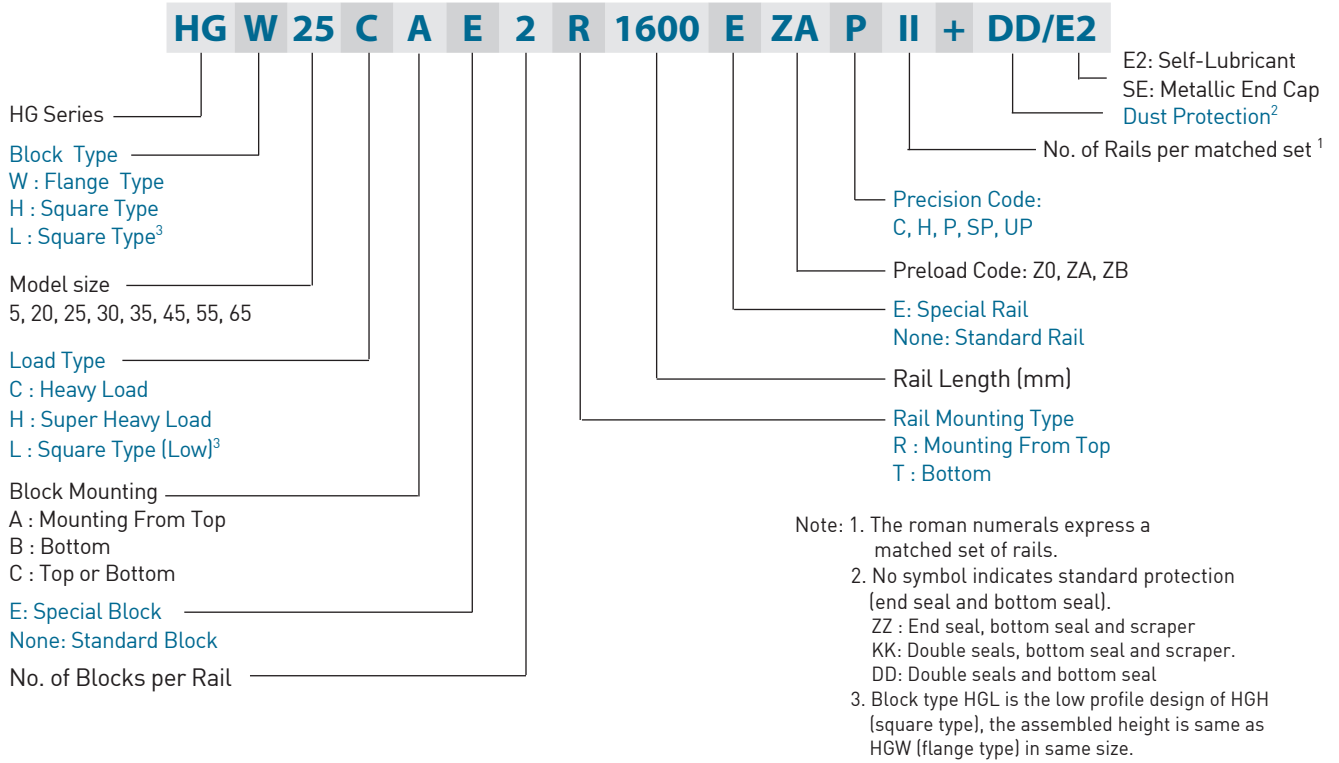

(2) Interchangeable type

○ Model Number of HG Block

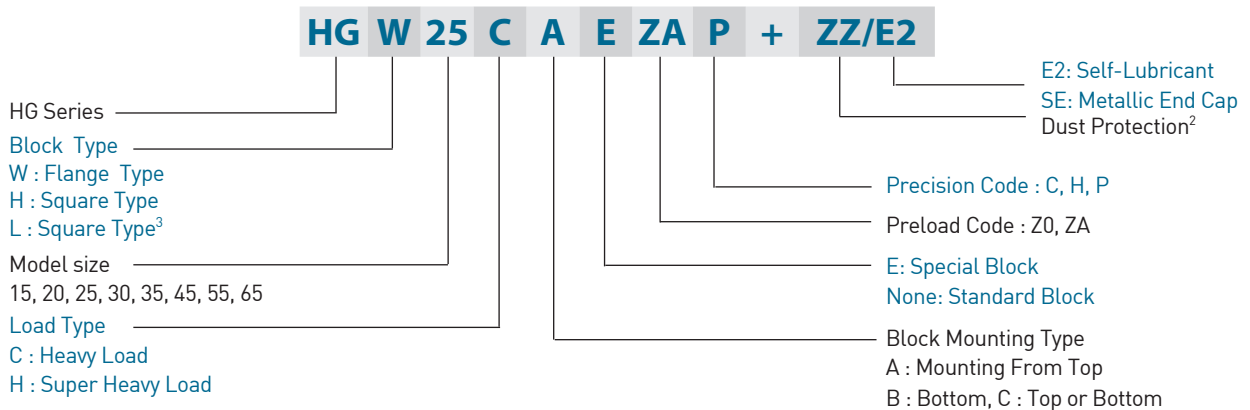

○ Model Number of HG Rail

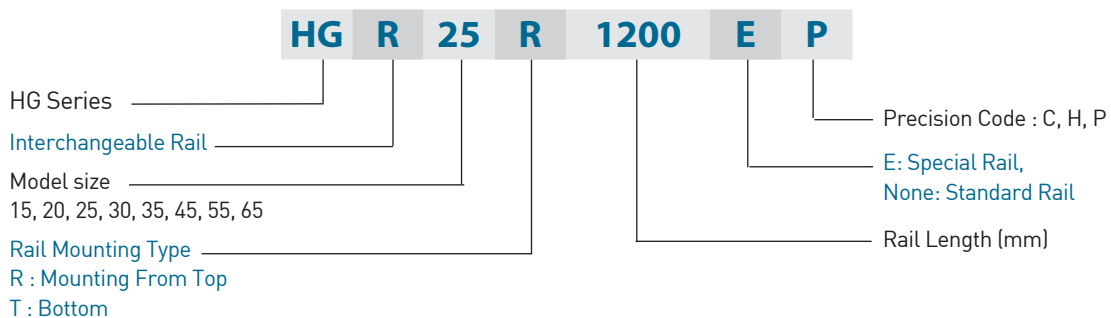

2-1-4 Types

(1) Block types

HIWIN offers two types of linear guideway which are flange and square types. Because of the low assembly height and larger mounting surface, the flange type is suitable for heavy moment load application.

Table 2.4 Block Types

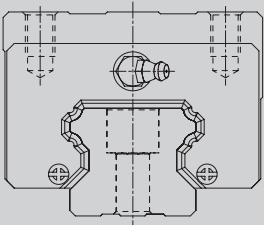
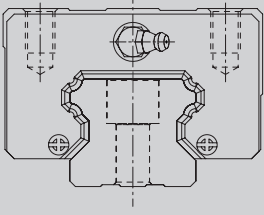
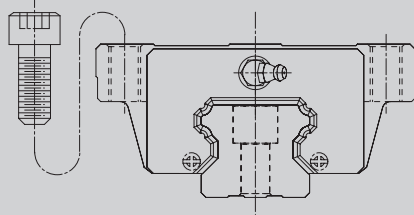
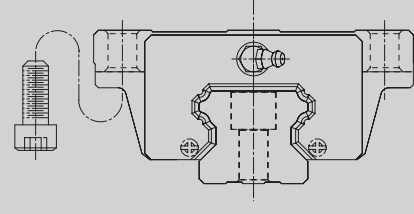
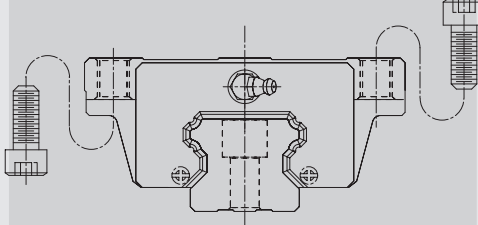
Type	Model	Shape	Height (mm)	Rail Length (mm)	Main Application
Square	HGH-CA HGH-HA		28 ↓ 90	100 ↓ 4000	<ul style="list-style-type: none"> ○ Machine Centers ○ NC Lathes ○ Grinding Machines ○ Precision Machining Machines ○ Heavy Cutting Machines ○ Automation Devices ○ Transportation Equipment ○ Measuring Equipment ○ Devices Requiring High Positional Accuracy
	HGL-CA HGL-HA		24 ↓ 70	100 ↓ 4000	
Flange	HGW-CA HGW-HA		24 ↓ 90	100 ↓ 4000	
	HGW-CB HGW-HB		24 ↓ 90	100 ↓ 4000	
	HGW-CC HGW-HC		24 ↓ 90	100 ↓ 4000	

Linear Guideways

HG Series

(2) Rail types

Besides the standard top mounting type, HIWIN also offers the bottom mounting type of rails to customers.

Table 2.5 Rail Types

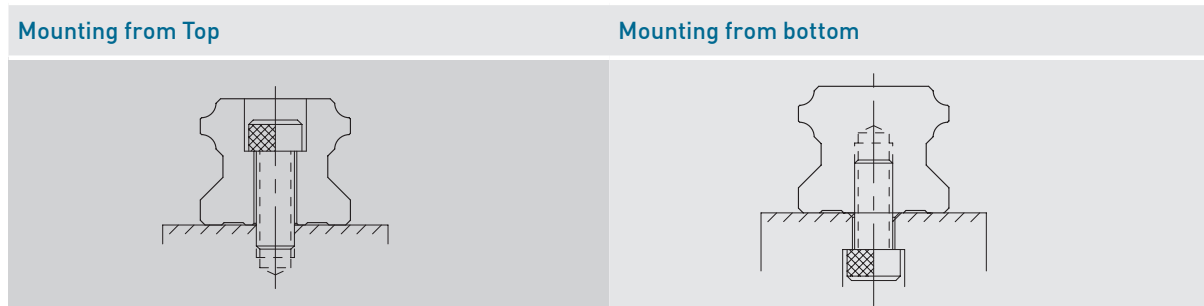

2-1-5 Accuracy Classes

The accuracy of HG series can be classified into normal (C), high (H), precision (P), super precision (SP), ultra precision (UP), five classes. Please choose the class by referring the accuracy of applied equipment.

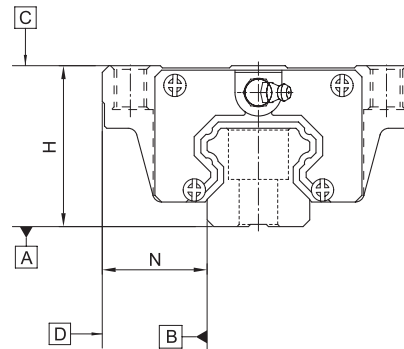

(1) Accuracy of non-interchangeable

Table 2.6 Accuracy Standards

Unit: mm

Item	HG - 15, 20				
	Normal (C)	High (H)	Precision (P)	Super Precision (SP)	Ultra Precision (UP)
Dimensional tolerance of height H	± 0.1	± 0.03	0 - 0.03	0 - 0.015	0 - 0.008
Dimensional tolerance of width N	± 0.1	± 0.03	0 - 0.03	0 - 0.015	0 - 0.008
Variation of height H	0.02	0.01	0.006	0.004	0.003
Variation of width N	0.02	0.01	0.006	0.004	0.003
Running parallelism of block surface C to surface A	See Table 2.14				
Running parallelism of block surface D to surface B	See Table 2.14				

Table 2.7 Accuracy Standards

Unit: mm

Item	HG - 25, 30, 35				
	Normal (C)	High (H)	Precision (P)	Super Precision (SP)	Ultra Precision (UP)
Dimensional tolerance of height H	± 0.1	± 0.04	0 - 0.04	0 - 0.02	0 - 0.01
Dimensional tolerance of width N	± 0.1	± 0.04	0 - 0.04	0 - 0.02	0 - 0.01
Variation of height H	0.02	0.015	0.007	0.005	0.003
Variation of width N	0.03	0.015	0.007	0.005	0.003
Running parallelism of block surface C to surface A	See Table 2.14				
Running parallelism of block surface D to surface B	See Table 2.14				

Table 2.8 Accuracy Standards

Unit: mm

Item	HG - 45, 55				
Accuracy Classes	Normal (C)	High (H)	Precision (P)	Super Precision (SP)	Ultra Precision (UP)
Dimensional tolerance of height H	± 0.1	± 0.05	0 - 0.05	0 - 0.03	0 - 0.02
Dimensional tolerance of width N	± 0.1	± 0.05	0 - 0.05	0 - 0.03	0 - 0.02
Variation of height H	0.03	0.015	0.007	0.005	0.003
Variation of width N	0.03	0.02	0.01	0.007	0.005
Running parallelism of block surface C to surface A	See Table 2.14				
Running parallelism of block surface D to surface B	See Table 2.14				

Table 2.9 Accuracy Standards

Unit: mm

Item	HG - 65				
Accuracy Classes	Normal (C)	High (H)	Precision (P)	Super Precision (SP)	Ultra Precision (UP)
Dimensional tolerance of height H	± 0.1	± 0.07	0 - 0.07	0 - 0.05	0 - 0.03
Dimensional tolerance of width N	± 0.1	± 0.07	0 - 0.07	0 - 0.05	0 - 0.03
Variation of height H	0.03	0.02	0.01	0.007	0.005
Variation of width N	0.03	0.025	0.015	0.01	0.007
Running parallelism of block surface C to surface A	See Table 2.14				
Running parallelism of block surface D to surface B	See Table 2.14				

(2) Accuracy of interchangeable

Table 2.10 Accuracy Standards

Unit: mm

Item	HG - 15, 20		
Accuracy Classes	Normal (C)	High (H)	Precision (P)
Dimensional tolerance of height H	± 0.1	± 0.03	± 0.015
Dimensional tolerance of width N	± 0.1	± 0.03	± 0.015
Variation of height H	0.02	0.01	0.006
Variation of width N	0.02	0.01	0.006
Running parallelism of block surface C to surface A	See Table 2.14		
Running parallelism of block surface D to surface B	See Table 2.14		

Table 2.11 Accuracy Standards

Unit: mm

Item	HG - 25, 30, 35		
Accuracy Classes	Normal (C)	High (H)	Precision (P)
Dimensional tolerance of height H	± 0.1	± 0.04	± 0.02
Dimensional tolerance of width N	± 0.1	± 0.04	± 0.02
Variation of height H	0.02	0.015	0.007
Variation of width N	0.03	0.015	0.007
Running parallelism of block surface C to surface A	See Table 2.14		
Running parallelism of block surface D to surface B	See Table 2.14		

Linear Guideways

HG Series

Table 2.12 Accuracy Standards

Unit: mm

Item	HG - 45, 55		
	Normal (C)	High (H)	Precision (P)
Dimensional tolerance of height H	± 0.1	± 0.05	± 0.025
Dimensional tolerance of width N	± 0.1	± 0.05	± 0.025
Variation of height H	0.03	0.015	0.007
Variation of width N	0.03	0.02	0.01
Running parallelism of block surface C to surface A	See Table 2.14		
Running parallelism of block surface D to surface B	See Table 2.14		

Table 2.13 Accuracy Standards

Unit: mm

Item	HG - 65		
	Normal (C)	High (H)	Precision (P)
Dimensional tolerance of height H	± 0.1	± 0.07	± 0.035
Dimensional tolerance of width N	± 0.1	± 0.07	± 0.035
Variation of height H	0.03	0.02	0.01
Variation of width N	0.03	0.025	0.015
Running parallelism of block surface C to surface A	See Table 2.14		
Running parallelism of block surface D to surface B	See Table 2.14		

(3) Accuracy of running parallelism

Table 2.14 Accuracy of Running Parallelism

Rail Length (mm)	Accuracy (µm)				
	C	H	P	SP	UP
~ 100	12	7	3	2	2
100 ~ 200	14	9	4	2	2
200 ~ 300	15	10	5	3	2
300 ~ 500	17	12	6	3	2
500 ~ 700	20	13	7	4	2
700 ~ 900	22	15	8	5	3
900 ~ 1,100	24	16	9	6	3
1,100 ~ 1,500	26	18	11	7	4
1,500 ~ 1,900	28	20	13	8	4
1,900 ~ 2,500	31	22	15	10	5
2,500 ~ 3,100	33	25	18	11	6
3,100 ~ 3,600	36	27	20	14	7
3,600 ~ 4,000	37	28	21	15	7

2-1-6 Preload

(1) Definition

A preload can be applied to each guideway. Oversized balls are used. Generally, a linear motion guideway has a negative clearance between groove and balls in order to improve stiffness and maintain high precision. The figure shows the load is multiplied by the preload, the rigidity is doubled and the deflection is reduced by one half. The preload not larger than ZA would be recommended for the model size under HG20 to avoid an over-preload affecting the guideway's life.

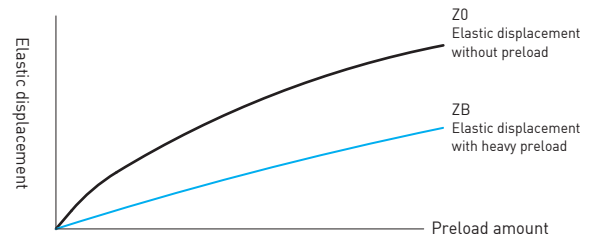

(2) Preload classes

HIWIN offers three classes of standard preload for various applications and conditions.

Table 2.15 Preload Classes

Class	Code	Preload	Condition	Examples of Application
Light Preload	Z0	0~0.02C	Certain load direction, low impact, low precision required	Transportation devices, auto-packing machines, X-Y axis for general industrial machines, welding machines, welders
Medium Preload	ZA	0.05~0.07C	High precision required	Machining centers, Z axis for general industrial machines, EDM, NC lathes, Precision X-Y tables, measuring equipment
Heavy Preload	ZB	0.10C~0.12C	High rigidity required, with vibration and impact	Machining centers, grinding machines, NC lathes, horizontal and vertical milling machines, Z axis of machine tools, Heavy cutting machines

Class	Interchangeable Guideway	Non-Interchangeable Guideway
Preload classes	Z0, ZA	Z0, ZA, ZB

Note: The "C" in the preload column denotes basic dynamic load rating.

2-1-7 Lubrication

(1) Grease

- Grease nipple

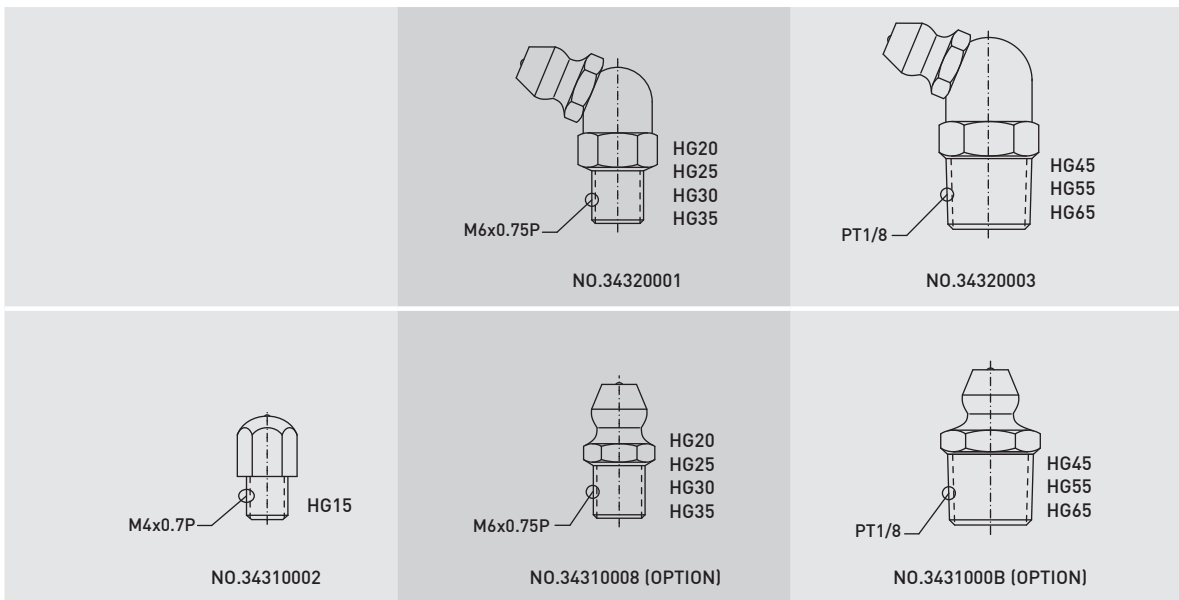

Linear Guideways

HG Series

○ Mounting location

The standard location of the grease fitting is at both ends of the block, but the nipple can be mounted at each side of block. For lateral installation, we recommend that the nipple be mounted at the non-reference side, otherwise please contact us. It is possible to perform lubrication by using the oil-piping joint.

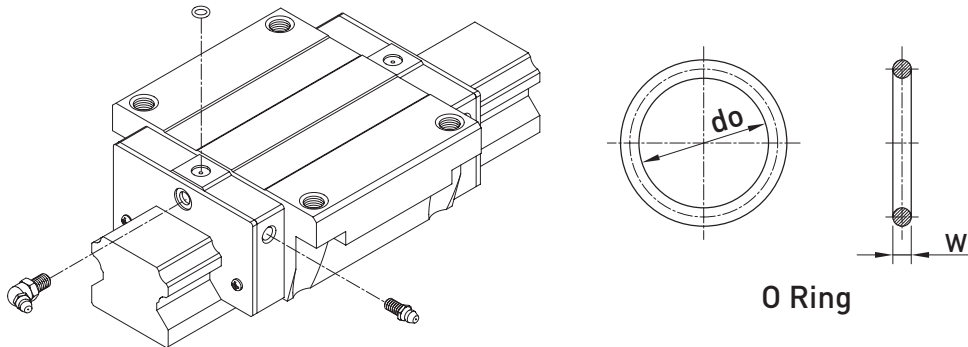

Table 2.16 O-Ring size and max. permissible depth for piercing

Size	O-Ring		Lube hole at top: max. permissible depth for piercing T_{max}
	do (mm)	W (mm)	
HG 15	2.5±0.15	1.5±0.15	3.75
HG 20	4.5±0.15	1.5±0.15	5.7
HG 25	4.5±0.15	1.5±0.15	5.8
HG 30	4.5±0.15	1.5±0.15	6.3
HG 35	4.5±0.15	1.5±0.15	8.8
HG 45	4.5±0.15	1.5±0.15	8.2
HG 55	4.5±0.15	1.5±0.15	11.8
HG 65	4.5±0.15	1.5±0.15	10.8

○ The lubricant amount for a block filled with grease

Table 2.17 The lubricant Amount for a Block Filled with Grease

Size	Heavy load (cm ³)	Super heavy load (cm ³)	Size	Heavy load (cm ³)	Super heavy load (cm ³)
HG 15	1	-	HG 35	10	12
HG 20	2	3	HG 45	17	21
HG 25	5	6	HG 55	26	33
HG 30	7	8	HG 65	50	61

○ Frequency of replenishment

Check the grease every 100 km, or every 3-6 months.

(2) Oil

The recommended viscosity of oil is about 30~150cSt. If customers need to use oil-type lubrication, please inform us, and the block will not be prelubricated with grease before shipment.

Types of oil piping joint

<p>LF-64</p> <p>NO.97000EA1 HG15</p>	<p>LF-76</p> <p>NO.970002A1 HG20 HG25 HG30 HG35</p>	<p>LF-78</p> <p>NO.970006A1 HG45 HG55 HG65</p>
<p>LF-86</p> <p>NO.970004A1 HG20 HG25 HG30 HG35</p>	<p>LF-88</p> <p>NO.970008A1 HG45 HG55 HG65</p>	
<p>SF-76</p> <p>NO.970001A1 HG20 HG25 HG30 HG35</p>	<p>SF-78</p> <p>NO.970005A1 HG45 HG55 HG65</p>	
<p>SF-86</p> <p>NO.970003A1 HG20 HG25 HG30 HG35</p>	<p>SF-88</p> <p>NO.970007A1 HG45 HG55 HG65</p>	

Linear Guideways

HG Series

Oil refilling rate

Table 2.18

Size	Refilling rate (cm ³ /hr)	Size	Refilling rate (cm ³ /hr)
HG 15	0.2	HG 35	0.3
HG 20	0.2	HG 45	0.4
HG 25	0.3	HG 55	0.5
HG 30	0.3	HG 65	0.6

2-1-8 Dust Proof Accessories

(1) Codes of accessories

If the following accessories are needed, please add the code followed by the model number.

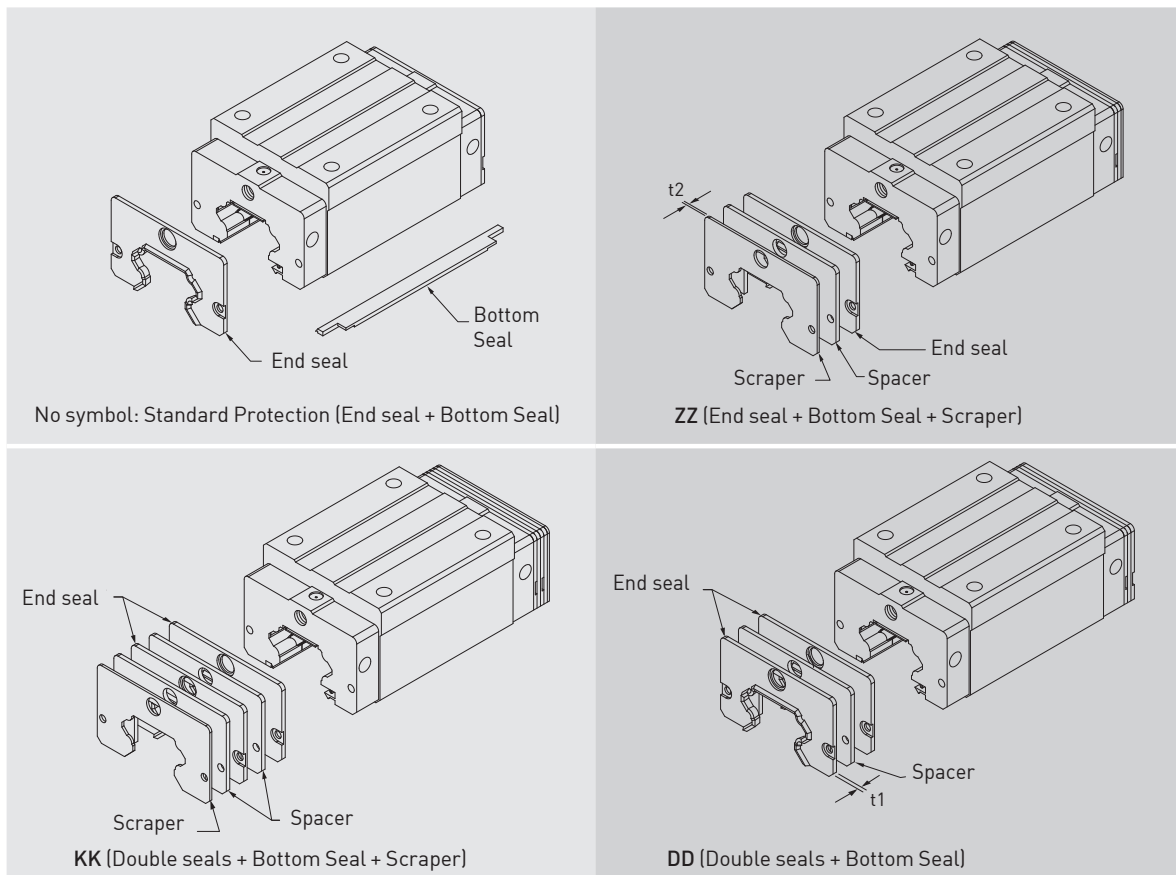

(2) End seal and bottom seal

To prevent life reduction caused by iron chips or dust entering the block.

(3) Double seals

Enhances the wiping effect, foreign matter can be completely wiped off.

Table 2.19 Dimensions of end seal

Size	Thickness (t1) (mm)	Size	Thickness (t1) (mm)
HG 15 ES	3	HG 35 ES	3.2
HG 20 ES	3.5	HG 45 ES	4.5
HG 25 ES	3.5	HG 55 ES	4.5
HG 30 ES	3.2	HG 65 ES	6

(4) Scraper

The scraper removes high-temperature iron chips and larger foreign objects.

Table 2.20 Dimensions of scraper

Size	Thickness (t2) (mm)	Size	Thickness (t2) (mm)
HG 15 SC	1.5	HG 35 SC	1.5
HG 20 SC	1.5	HG 45 SC	1.5
HG 25 SC	1.5	HG 55 SC	1.5
HG 30 SC	1.5	HG 65 SC	1.5

(5) Bolt caps for rail mounting holes

Caps are used to cover the mounting holes to prevent chips or other foreign objects from collecting in the holes. The caps will be enclosed in each rail package.

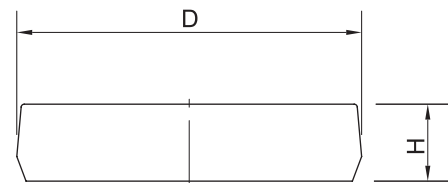

Table 2.21 Dimensions of Bolt Caps for Rail Mounting Holes

Rail size	Bolt size	Diameter(D) (mm)	Thickness(H) (mm)	Rail size	Bolt size	Diameter(D) (mm)	Thickness(H) (mm)
HGR15	M4	7.65	1.1	HGR35	M8	14.30	3.3
HGR20	M5	9.65	2.2	HGR45	M12	20.25	4.6
HGR25	M6	11.20	2.5	HGR55	M14	23.50	5.5
HGR30	M8	14.25	3.3	HGR65	M16	26.60	5.5

Linear Guideways

HG Series

(6) Dust Proof Accessories

HIWIN develops many kinds of dust proof accessories for different application and working environment to avoid dust or debris. If the following accessories are needed, please add the code followed by the model number.

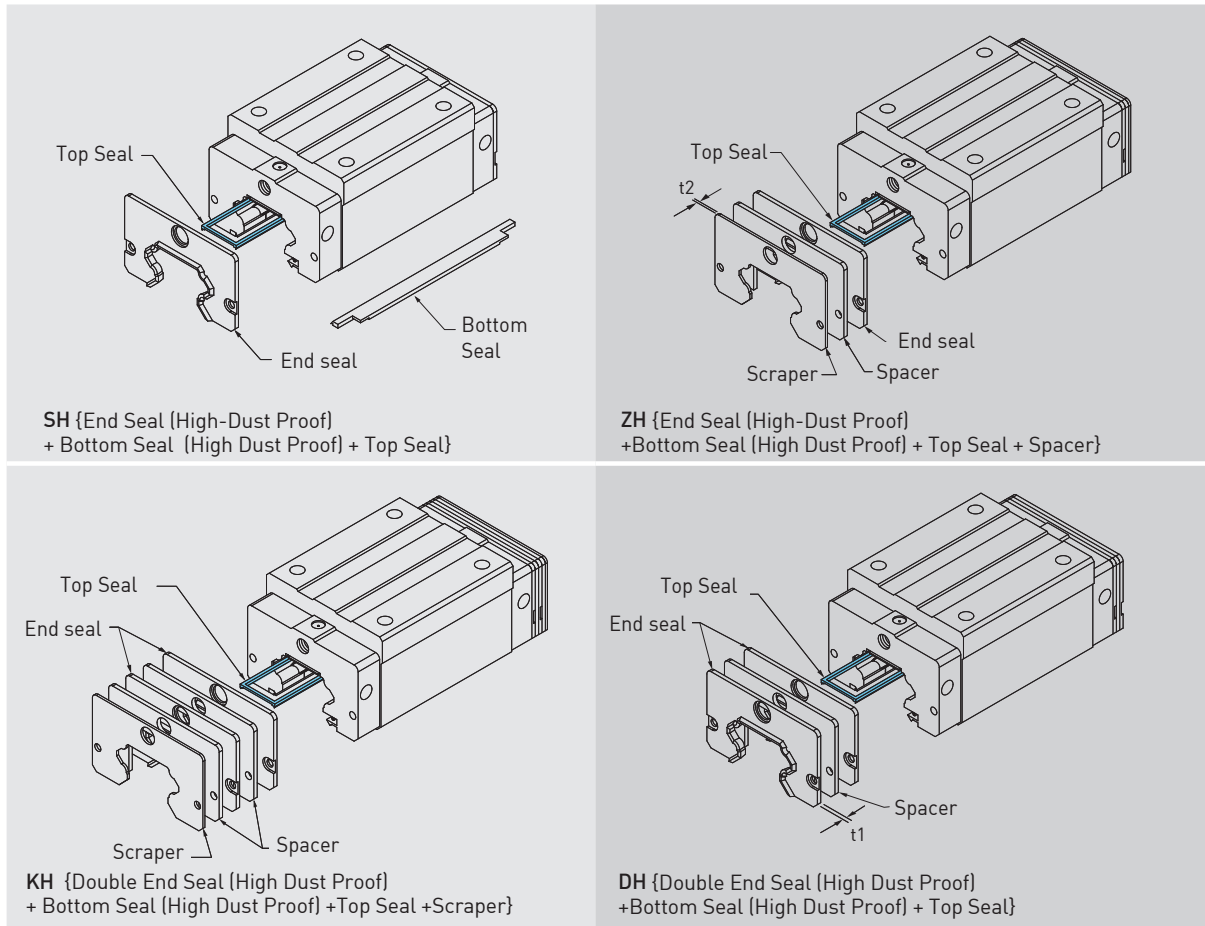

- Note :
1. The available size for high dust proof accessories are HG20(C/H), 25(C/H), 30(C/H), 35(C/H) and 45C.
 2. The friction value will increase 0.6~1.2 kgf comparing to normal type.
 3. If any higher dust proof requirement is needed, please contact with HIWIN.

(7) Top Seal

Top seal can efficiently avoid dust from the surface of rail or tapping hole getting inside the block.

2-1-9 Friction

The maximum value of resistance per end seal are as shown in the table.

Table 2.22 Seal Resistance

Size	Resistance N (kgf)	Size	Resistance N (kgf)
HG15	12.23 [0.12]	HG35	31.6 [0.31]
HG20	16.31 [0.16]	HG45	39.8 [0.39]
HG25	20.38 [0.2]	HG55	47.9 [0.47]
HG30	27.53 [0.27]	HG65	60.15 [0.59]

2-1-10 The Accuracy Tolerance of Mounting Surface

(1) The accuracy tolerance of rail-mounting surface

Because of the Circular-arc contact design, the HG linear guideway can compensate for some surface-error on installation and still maintain smooth linear motion.

As long as the accuracy requirements for the mounting surface are followed, high accuracy and rigidity of linear motion of the guideway can be obtained without any difficulty. In order to satisfy the needs of fast installation and smooth movement, HIWIN offers the normal clearance type of preload to customers of its high absorption ability of the deviation in mounting surface accuracy.

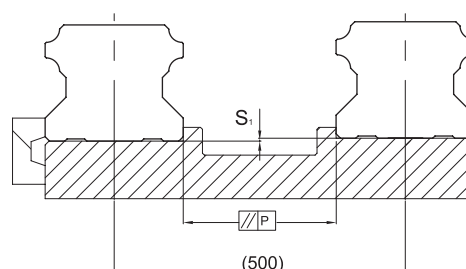

(2) The parallelism tolerance of reference surface (P)

Table 2.23 Max. Parallelism Tolerance (P)

unit: μm

Size	Preload classes		
	Z0	ZA	ZB
HG15	25	18	-
HG20	25	20	18
HG25	30	22	20
HG30	40	30	27
HG35	50	35	30
HG45	60	40	35
HG55	70	50	45
HG65	80	60	55

(3) The accuracy tolerance of reference surface height

Table 2.24 Max. Tolerance of Reference Surface Height (S₁)

unit: μm

Size	Preload classes		
	Z0	ZA	ZB
HG15	130	85	-
HG20	130	85	50
HG25	130	85	70
HG30	170	110	90
HG35	210	150	120
HG45	250	170	140
HG55	300	210	170
HG65	350	250	200

Linear Guideways

HG Series

2-1-11 Cautions for Installation

(1) Shoulder heights and fillets

Improper shoulder heights and fillets of mounting surfaces will cause a deviation in accuracy and the interference with the chamfered part of the rail or block. As long as the recommended shoulder heights and fillets are followed, installation inaccuracies should be eliminated.

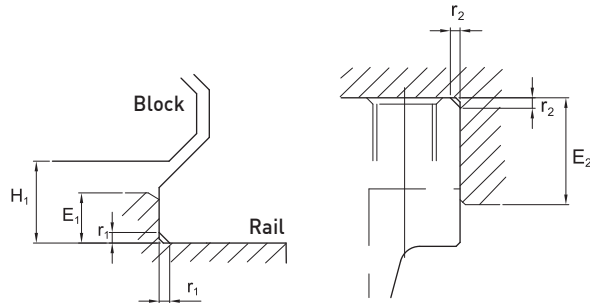

Table 2.25 Shoulder Heights and Fillets

Size	Max. radius of fillets	Max. radius of fillets	Shoulder height of the rail	Shoulder height of the block	Clearance under block
	r_1 (mm)	r_2 (mm)	E_1 (mm)	E_2 (mm)	
HG15	0.5	0.5	3	4	4.3
HG20	0.5	0.5	3.5	5	4.6
HG25	1.0	1	5	5	5.5
HG30	1.0	1	5	5	6
HG35	1.0	1	6	6	7.5
HG45	1.0	1	8	8	9.5
HG55	1.5	1.5	10	10	13
HG65	1.5	1.5	10	10	15

(2) Tightening Torque of Bolts for Installation

Improper tightening of bolts will seriously influence the accuracy of Linear Guideway installation. The following tightening torques for different sizes of bolts are recommended.

Table 2.26 Mounting Torque

Size	Bolt size	Torque N-cm (kgf-cm)	Size	Bolt size	Torque N-cm (kgf-cm)
HG 15	M4 x 0.7P x 16L	392 (40)	HG 35	M8 x 1.25P x 25L	3,041 (310)
HG 20	M5 x 0.8P x 16L	883 (90)	HG 45	M12 x 1.75P x 35L	11,772 (1,200)
HG 25	M6 x 1P x 20L	1373 (140)	HG 55	M14 x 2P x 45L	15,696 (1,600)
HG 30	M8 x 1.25P x 25L	3041 (310)	HG 65	M16 x 2P x 50L	19,620 (2,000)

2-1-12 Standard and Maximum Lengths of Rail

HIWIN offers standard rail lengths for customer needs. For non-standard E-values, the recommended dimension should not be greater than 1/2 of the pitch (P) dimension. This will prevent an unstable rail end.

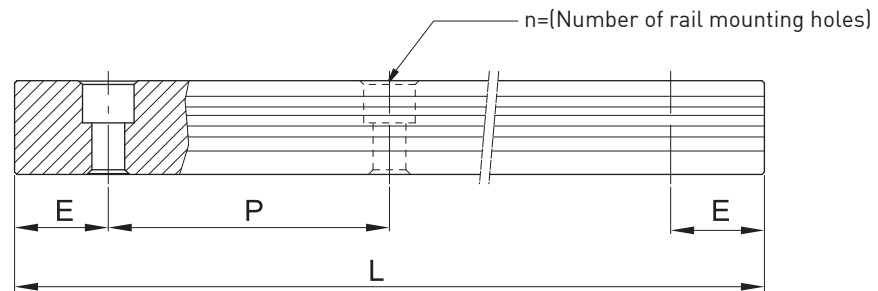

$$L = (n - 1) \times P + 2 \times E \quad \dots \dots \dots \text{Eq.2.1}$$

- L : Total length of rail (mm)
- n : Number of mounting holes
- P : Distance between any two holes (mm)
- E : Distance from the center of the last hole to the edge (mm)

Table 2.27 Rail Standard Length and Max. Length

unit: mm

Item	HG15	HG20	HG25	HG30	HG35	HG45	HG55	HG65
Standard Length L(n)	160 (3)	220 (4)	220 (4)	280 (4)	280 (4)	570 (6)	780 (7)	1,270 (9)
	220 (4)	280 (5)	280 (5)	440 (6)	440 (6)	885 (9)	1,020 (9)	1,570 (11)
	280 (5)	340 (6)	340 (6)	600 (8)	600 (8)	1,200 (12)	1,260 (11)	2,020 (14)
	340 (6)	460 (8)	460 (8)	760 (10)	760 (10)	1,620 (16)	1,500 (13)	2,620 (18)
	460 (8)	640 (11)	640 (11)	1,000 (13)	1,000 (13)	2,040 (20)	1,980 (17)	
	640 (11)	820 (14)	820 (14)	1,640 (21)	1,640 (21)	2,460 (24)	2,580 (22)	
	820 (14)	1,000 (17)	1,000 (17)	2,040 (26)	2,040 (26)	2,985 (29)	2,940 (25)	
		1,240 (21)	1,240 (21)	2,520 (32)	2,520 (32)			
		1,600 (27)	3,000 (38)	3,000 (38)				
Pitch (P)	60	60	60	80	80	105	120	150
Distance to End (E _s)	20	20	20	20	20	22.5	30	35
Max. Standard Length	1,960 (33)	4,000 (67)	4,000 (67)	3,960 (50)	3,960 (50)	3,930 (38)	3,900 (33)	3,970 (27)
Max. Length	2,000	4,000	4,000	4,000	4,000	4,000	4,000	4,000

- Note :
1. Tolerance of E value for standard rail is 0.5~0.5 mm. Tolerance of E value for jointed rail is 0~0.3 mm.
 2. Maximum standard length means the max. rail length with standard E value on both sides.
 3. If different E value is needed, please contact HIWIN.

Linear Guideways

HG Series

2-1-13 Dimensions for HIWIN HG Series

(1) HGH-CA / HGH-HA

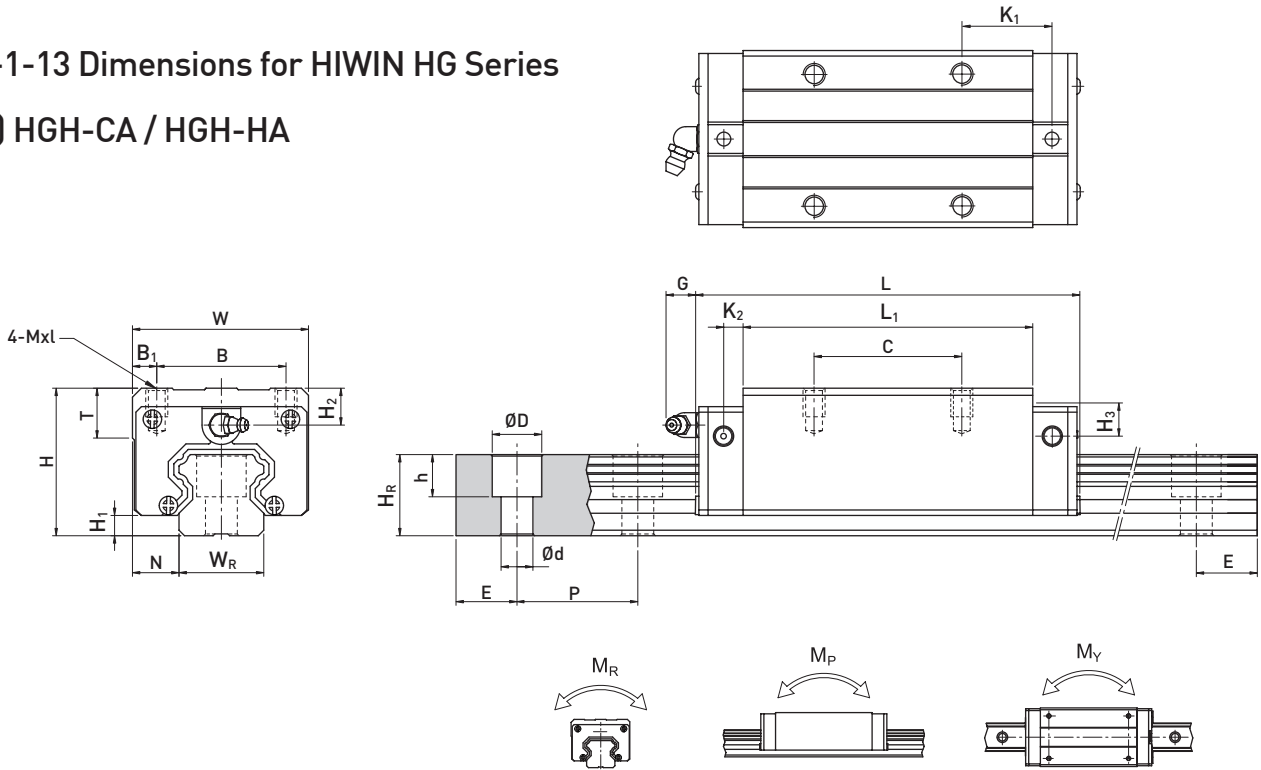

Model No.	Dimensions of Assembly (mm)				Dimensions of Block (mm)										Dimensions of Rail (mm)					Mounting Bolt for Rail (mm)	Basic Dynamic Load Rating C (kN)	Basic Static Load Rating C ₀ (kN)	Static Rated Moment			Weight					
	H	H ₁	N	W	B	B ₁	C	L ₁	L	K ₁	K ₂	G	Mxl	T	H ₂	H ₃	W _R	H _R	D				h	d	P	E	M _R	M _P	M _Y	Block kg	Rail kg/m
																												kN-m	kN-m	kN-m	kg
HGH 15CA	28	4.3	9.5	34	26	4	26	39.4	61.4	10	4.85	5.3	M4x5	6	7.95	7.7	15	15	7.5	5.3	4.5	60	20	M4x16	11.38	16.97	0.12	0.10	0.10	0.18	1.45
HGH 20CA	30	4.6	12	44	32	6	36	50.5	77.5	12.25	6	12	M5x6	8	6	7	20	17.5	9.5	8.5	6	60	20	M5x16	17.75	27.76	0.27	0.20	0.20	0.30	2.21
HGH 20HA							50	65.2	92.2	12.6															21.18	35.90	0.35	0.35	0.35	0.39	
HGH 25CA	40	5.5	12.5	48	35	6.5	35	58	84	16.8	6	12	M6x8	8	10	13	23	22	11	9	7	60	20	M6x20	26.48	36.49	0.42	0.33	0.33	0.51	3.21
HGH 25HA							50	78.6	104.6	19.6															32.75	49.44	0.56	0.57	0.57	0.69	
HGH 30CA	45	6	16	60	40	10	40	70	97.4	20.25	6	12	M8x10	8.5	9.5	13.8	28	26	14	12	9	80	20	M8x25	38.74	52.19	0.66	0.53	0.53	0.88	4.47
HGH 30HA							60	93	120.4	21.75															47.27	69.16	0.88	0.92	0.92	1.16	
HGH 35CA	55	7.5	18	70	50	10	50	80	112.4	20.6	7	12	M8x12	10.2	16	19.6	34	29	14	12	9	80	20	M8x25	49.52	69.16	1.16	0.81	0.81	1.45	6.30
HGH 35HA							72	105.8	138.2	22.5															60.21	91.63	1.54	1.40	1.40	1.92	
HGH 45CA	70	9.5	20.5	86	60	13	60	97	139.4	23	10	12.9	M10x17	16	18.5	30.5	45	38	20	17	14	105	22.5	M12x35	77.57	102.71	1.98	1.55	1.55	2.73	10.41
HGH 45HA							80	128.8	171.2	28.9															94.54	136.46	2.63	2.68	2.68	3.61	
HGH 55CA	80	13	23.5	100	75	12.5	75	117.7	166.7	27.35	11	12.9	M12x18	17.5	22	29	53	44	23	20	16	120	30	M14x45	114.44	148.33	3.69	2.64	2.64	4.17	15.08
HGH 55HA							95	155.8	204.8	36.4															139.35	196.20	4.88	4.57	4.57	5.49	
HGH 65CA	90	15	31.5	126	76	25	70	144.2	200.2	43.1	14	12.9	M16x20	25	15	15	63	53	26	22	18	150	35	M16x50	163.63	215.33	6.65	4.27	4.27	7.00	21.18
HGH 65HA							120	203.6	259.6	47.8															208.36	303.13	9.38	7.38	7.38	9.82	

Note : 1 kgf = 9.81 N

(2) HGL-CA/HGL-HA

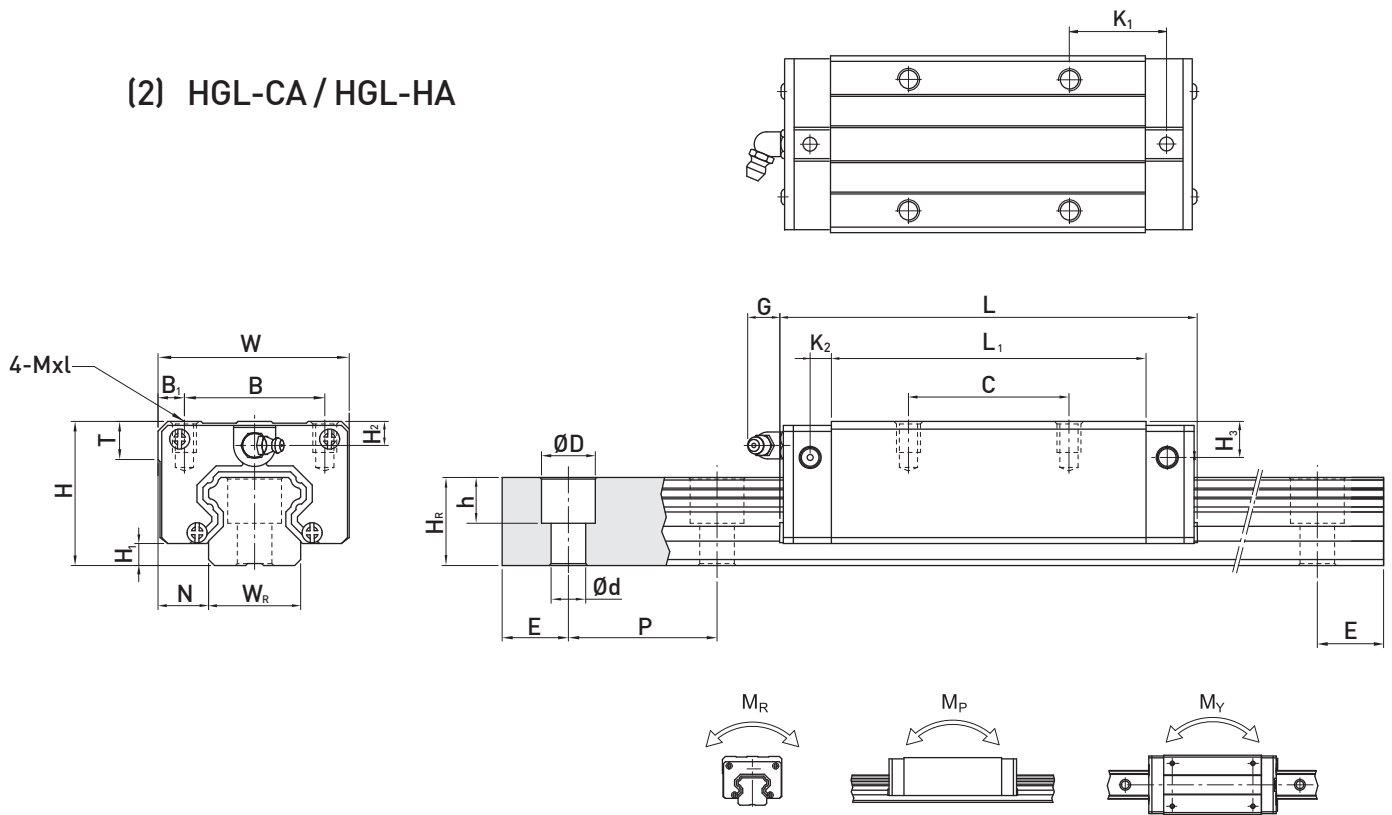

Model No.	Dimensions of Assembly (mm)		Dimensions of Block (mm)														Dimensions of Rail (mm)						Mounting Bolt for Rail (mm)	Basic Dynamic Load Rating C(kN)	Basic Static Load Rating C ₀ (kN)	Static Rated Moment			Weight		
	H	H ₁	N	W	B	B ₁	C	L ₁	L	K ₁	K ₂	G	Mxl	T	H ₂	H ₃	W _R	H _R	D	h	d	P				E	M _R	M _P	M _Y	Block kg	Rail kg/m
	kN-m			kN-m			kN-m			kg		kg/m																			
HGL 15CA	24	4.3	9.5	34	26	4	26	39.4	61.4	10	4.85	5.3	M4x4	6	3.95	3.7	15	15	7.5	5.3	4.5	60	20	M4x16	11.38	16.97	0.12	0.10	0.10	0.14	1.45
HGL 25CA	36	5.5	12.5	48	35	6.5	35	58	84	16.8	6	12	M6x6	8	6	9	23	22	11	9	7	60	20	M6x20	26.48	36.49	0.42	0.33	0.33	0.42	3.21
HGL 25HA							50	78.6	104.6	19.6															32.75	49.44	0.56	0.57	0.57	0.57	
HGL 30CA	42	6	16	60	40	10	40	70	97.4	20.25	6	12	M8x10	8.5	6.5	10.8	28	26	14	12	9	80	20	M8x25	38.74	52.19	0.66	0.53	0.53	0.78	4.47
HGL 30HA							60	93	120.4	21.75															47.27	69.16	0.88	0.92	0.92	1.03	
HGL 35CA	48	7.5	18	70	50	10	50	80	112.4	20.6	7	12	M8x12	10.2	9	12.6	34	29	14	12	9	80	20	M8x25	49.52	69.16	1.16	0.81	0.81	1.14	6.30
HGL 35HA							72	105.8	138.2	22.5															60.21	91.63	1.54	1.40	1.40	1.52	
HGL 45CA	60	9.5	20.5	86	60	13	60	97	139.4	23	10	12.9	M10x17	16	8.5	20.5	45	38	20	17	14	105	22.5	M12x35	77.57	102.71	1.98	1.55	1.55	2.08	10.41
HGL 45HA							80	128.8	171.2	28.9															94.54	136.46	2.63	2.68	2.68	2.75	
HGL 55CA	70	13	23.5	100	75	12.5	75	117.7	166.7	27.35	11	12.9	M12x18	17.5	12	19	53	44	23	20	16	120	30	M14x45	114.44	148.33	3.69	2.64	2.64	3.25	15.08
HGL 55HA							95	155.8	204.8	36.4															139.35	196.20	4.88	4.57	4.57	4.27	

Note : 1 kgf = 9.81 N

Linear Guideways

HG Series

(3) HGW-CA / HGW-HA

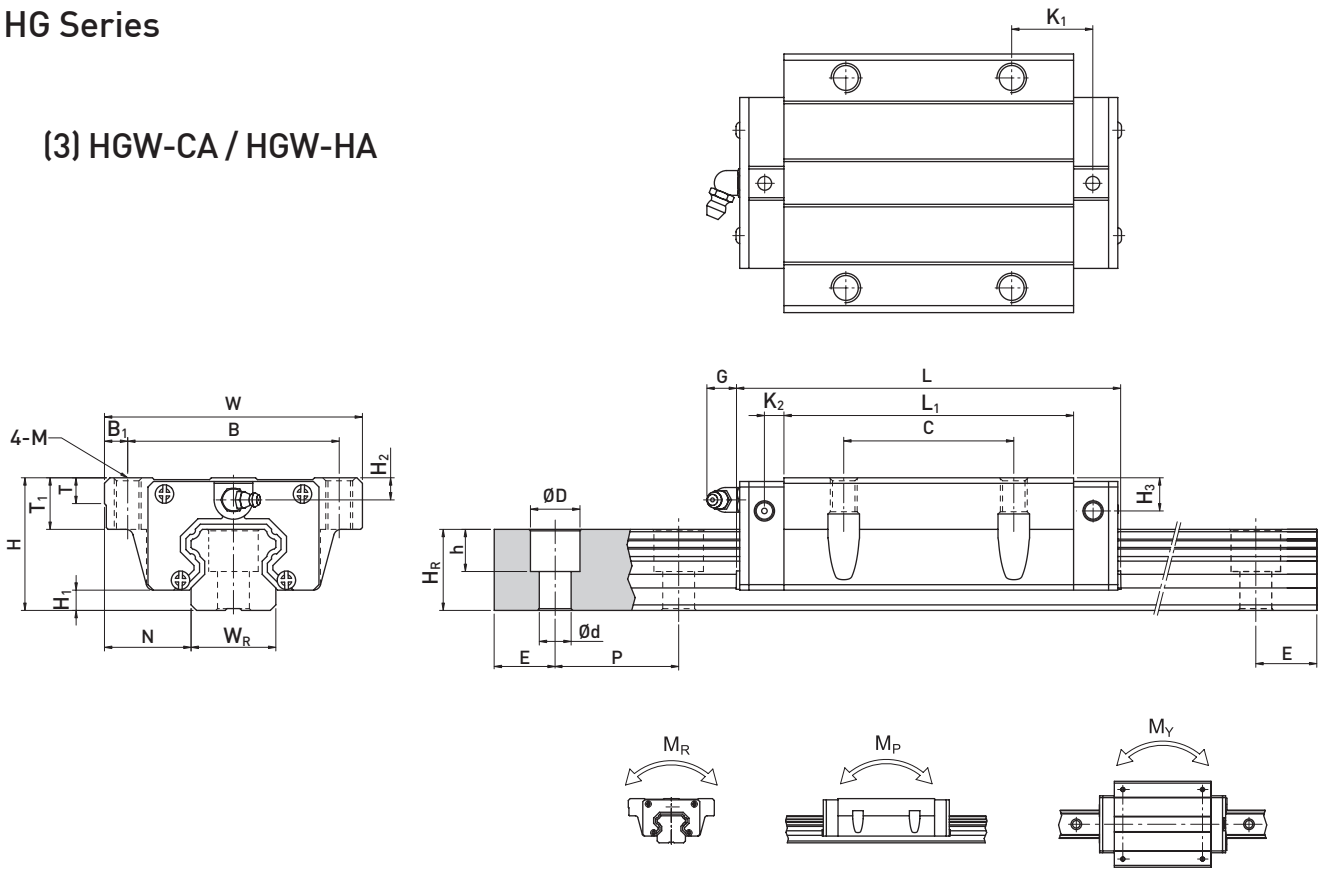

Model No.	Dimensions of Assembly (mm)		Dimensions of Block (mm)															Dimensions of Rail (mm)					Mounting Bolt for Rail (mm)	Basic Dynamic Load Rating C(kN)	Basic Static Load Rating C0(kN)	Static Rated Moment			Weight			
	H	H1	N	W	B	B1	C	L1	L	K1	K2	G	M	T	T1	H2	H3	WR	HR	D	h	d				P	E	MR	MP	MY	Block kg	Rail kg/m
HGW 15CA	24	4.3	16	47	38	4.5	30	39.4	61.4	8	4.85	5.3	M5	6	8.9	3.95	3.7	15	15	7.5	5.3	4.5	60	20	M4x16	11.38	16.97	0.12	0.10	0.10	0.17	1.45
HGW 20CA	30	4.6	21.5	63	53	5	40	50.5	77.5	10.25	6	12	M6	8	10	6	7	20	17.5	9.5	8.5	6	60	20	M5x16	17.75	27.76	0.27	0.20	0.20	0.40	2.21
HGW 20HA								65.2	92.2	17.6																21.18	35.90	0.35	0.35	0.35	0.52	
HGW 25CA	36	5.5	23.5	70	57	6.5	45	58	84	11.8	6	12	M8	8	14	6	9	23	22	11	9	7	60	20	M6x20	26.48	36.49	0.42	0.33	0.33	0.59	3.21
HGW 25HA								78.6	104.6	22.1																32.75	49.44	0.56	0.57	0.57	0.80	
HGW 30CA	42	6	31	90	72	9	52	70	97.4	14.25	6	12	M10	8.5	16	6.5	10.8	28	26	14	12	9	80	20	M8x25	38.74	52.19	0.66	0.53	0.53	1.09	4.47
HGW 30HA								93	120.4	25.75																47.27	69.16	0.88	0.92	0.92	1.44	
HGW 35CA	48	7.5	33	100	82	9	62	80	112.4	14.6	7	12	M10	10.1	18	9	12.6	34	29	14	12	9	80	20	M8x25	49.52	69.16	1.16	0.81	0.81	1.56	6.30
HGW 35HA								105.8	138.2	27.5																60.21	91.63	1.54	1.40	1.40	2.06	
HGW 45CA	60	9.5	37.5	120	100	10	80	97	139.4	13	10	12.9	M12	15.1	22	8.5	20.5	45	38	20	17	14	105	22.5	M12x35	77.57	102.71	1.98	1.55	1.55	2.79	10.41
HGW 45HA								128.8	171.2	28.9																94.54	136.46	2.63	2.68	2.68	3.69	
HGW 55CA	70	13	43.5	140	116	12	95	117.7	166.7	17.35	11	12.9	M14	17.5	26.5	12	19	53	44	23	20	16	120	30	M14x45	114.44	148.33	3.69	2.64	2.64	4.52	15.08
HGW 55HA								155.8	204.8	36.4																139.35	196.20	4.88	4.57	4.57	5.96	
HGW 65CA	90	15	53.5	170	142	14	110	144.2	200.2	23.1	14	12.9	M16	25	37.5	15	15	63	53	26	22	18	150	35	M16x50	163.63	215.33	6.65	4.27	4.27	9.17	21.18
HGW 65HA								203.6	259.6	52.8																208.36	303.13	9.38	7.38	7.38	12.89	

Note : 1 kgf = 9.81 N

(4) HGW-CB / HGW-HB

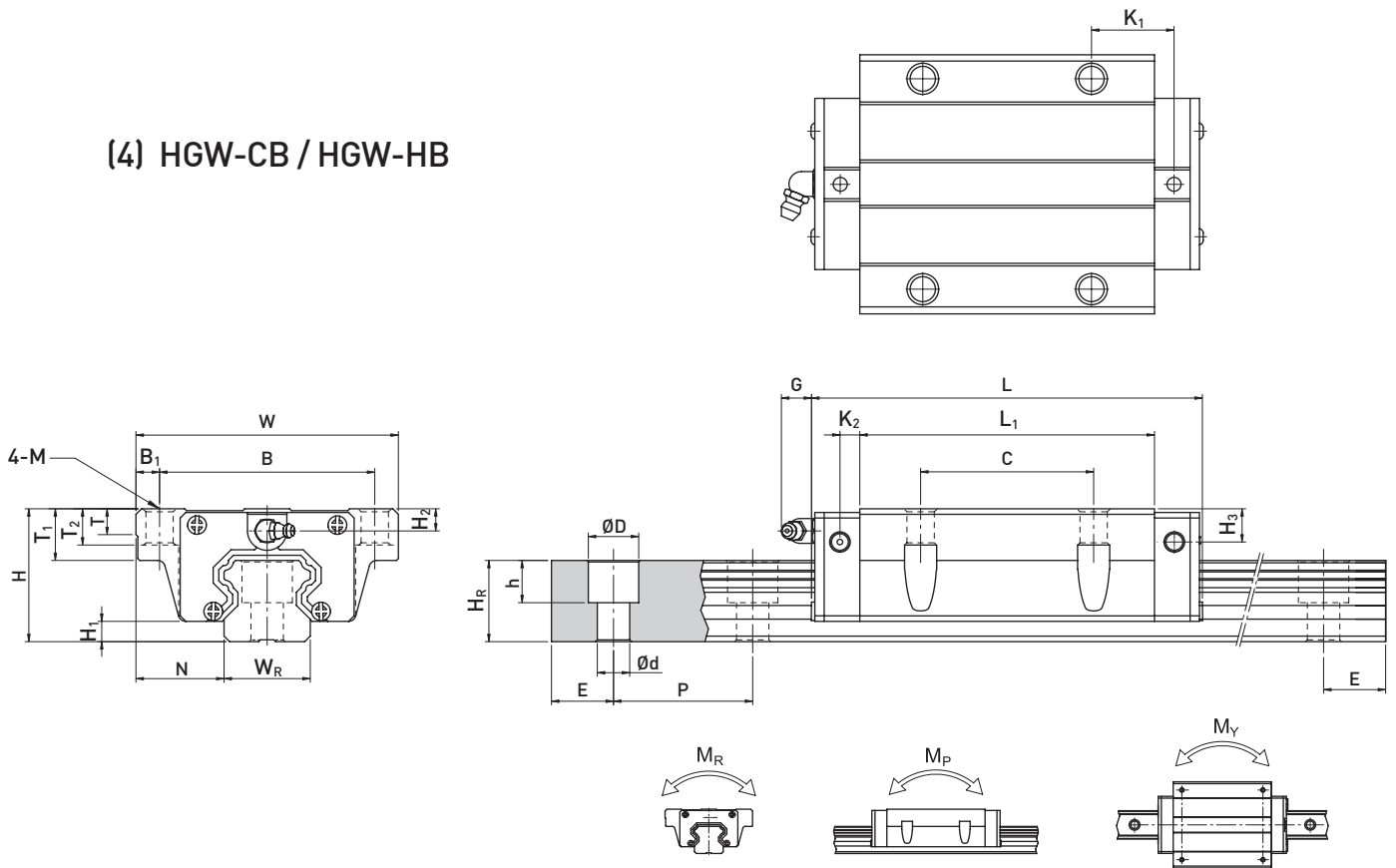

Model No.	Dimensions of Assembly (mm)		Dimensions of Block (mm)														Dimensions of Rail (mm)					Mounting Bolt for Rail (mm)	Basic Dynamic Load Rating C ₀ (kN)	Basic Static Load Rating C ₀ (kN)	Static Rated Moment			Weight						
	H	H ₁	N	W	B	B ₁	C	L ₁	L	K ₁	K ₂	G	M	T	T ₁	T ₂	H ₂	H ₃	W _R	H _R	D				h	d	P	E	M _R	M _P	M _Y	Block	Rail	
	kN-m			kN-m			kN-m			kg	kg/m																							
HGW 15CB	24	4.3	16	47	38	4.5	30	39.4	61.4	8	4.85	5.3	Ø4.5	6	8.9	6.95	3.95	3.7	15	15	7.5	5.3	4.5	60	20	M4x16	11.38	16.97	0.12	0.10	0.10	0.17	1.45	
HGW 20CB	30	4.6	21.5	63	53	5	40	50.5	77.5	10.25	6	12	Ø6	8	10	9.5	6	7	20	17.5	9.5	8.5	6	60	20	M5x16	17.75	27.76	0.27	0.20	0.20	0.40	2.21	
HGW 20HB								65.2	92.2	17.6																								
HGW 25CB	36	5.5	23.5	70	57	6.5	45	58	84	11.8	6	12	Ø7	8	14	10	6	9	23	22	11	9	7	60	20	M6x20	26.48	36.49	0.42	0.33	0.33	0.59	3.21	
HGW 25HB								78.6	104.6	22.1																								
HGW 30CB	42	6	31	90	72	9	52	70	97.4	14.25	6	12	Ø9	8.5	16	10	6.5	10.8	28	26	14	12	9	80	20	M8x25	38.74	52.19	0.66	0.53	0.53	1.09	4.47	
HGW 30HB								93	120.4	25.75																								
HGW 35CB	48	7.5	33	100	82	9	62	80	112.4	14.6	7	12	Ø9	10.1	18	13	9	12.6	34	29	14	12	9	80	20	M8x25	49.52	69.16	1.16	0.81	0.81	1.56	6.30	
HGW 35HB								105.8	138.2	27.5																								
HGW 45CB	60	9.5	37.5	120	100	10	80	97	139.4	13	10	12.9	Ø11	15.1	22	15	8.5	20.5	45	38	20	17	14	105	22.5	M12x35	77.57	102.71	1.98	1.55	1.55	2.79	10.41	
HGW 45HB								128.8	171.2	28.9																								
HGW 55CB	70	13	43.5	140	116	12	95	117.7	166.7	17.35	11	12.9	Ø14	17.5	26.5	17	12	19	53	44	23	20	16	120	30	M14x45	114.44	148.33	3.69	2.64	2.64	4.52	15.08	
HGW 55HB								155.8	204.8	36.4																								
HGW 65CB	90	15	53.5	170	142	14	110	144.2	200.2	23.1	14	12.9	Ø16	25	37.5	23	15	15	63	53	26	22	18	150	35	M16x50	163.63	215.33	6.65	4.27	4.27	9.17	21.18	
HGW 65HB								203.6	259.6	52.8																								

Note : 1 kgf = 9.81 N

Linear Guideways

HG Series

(5) HGW-CC / HGW-HC

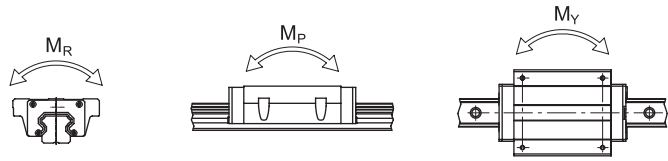
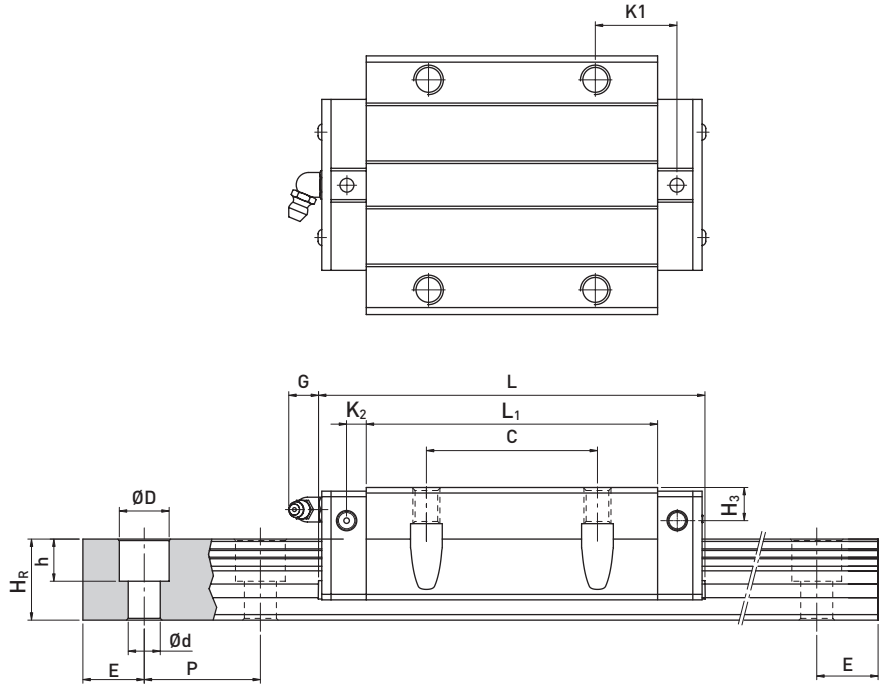
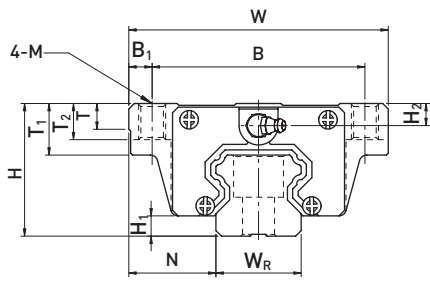

Model No.	Dimensions of Assembly (mm)		Dimensions of Block (mm)															Dimensions of Rail (mm)					Mounting Bolt for Rail (mm)	Basic Dynamic Load Rating C(kN)	Basic Static Load Rating C ₀ (kN)	Static Rated Moment			Weight				
	H	H ₁	N	W	B	B ₁	C	L ₁	L	K ₁	K ₂	G	M	T	T ₁	T ₂	H ₂	H ₃	W _R	H _R	D	h				d	P	E	M _R (kN-m)	M _P (kN-m)	M _Y (kN-m)	Block (kg)	Rail (kg/m)
	HGW 15CC	24	4.3	16	47	38	4.5	30	39.4	61.4	8	4.85	5.3	M5	6	8.9	6.95	3.95	3.7	15	15	7.5				5.3	4.5	60	20	M4x16	11.38	16.97	0.12
HGW 20CC	30	4.6	21.5	63	53	5	40	50.5	77.5	10.25	6	12	M6	8	10	9.5	6	7	20	17.5	9.5	8.5	6	60	20	M5x16	17.75	27.76	0.27	0.20	0.20	0.40	2.21
HGW 20HC								65.2	92.2	17.6																	21.18	35.90	0.35	0.35	0.35	0.52	
HGW 25CC	36	5.5	23.5	70	57	6.5	45	58	84	11.8	6	12	M8	8	14	10	6	9	23	22	11	9	7	60	20	M6x20	26.48	36.49	0.42	0.33	0.33	0.59	3.21
HGW 25HC								78.6	104.6	22.1																	32.75	49.44	0.56	0.57	0.57	0.80	
HGW 30CC	42	6	31	90	72	9	52	70	97.4	14.25	6	12	M10	8.5	16	10	6.5	10.8	28	26	14	12	9	80	20	M8x25	38.74	52.19	0.66	0.53	0.53	1.09	4.47
HGW 30HC								93	120.4	25.75																	47.27	69.16	0.88	0.92	0.92	1.44	
HGW 35CC	48	7.5	33	100	82	9	62	80	112.4	14.6	7	12	M10	10.1	18	13	9	12.6	34	29	14	12	9	80	20	M8x25	49.52	69.16	1.16	0.81	0.81	1.56	6.30
HGW 35HC								105.8	138.2	27.5																	60.21	91.63	1.54	1.40	1.40	2.06	
HGW 45CC	60	9.5	37.5	120	100	10	80	97	139.4	13	10	12.9	M12	15.1	22	15	8.5	20.5	45	38	20	17	14	105	22.5	M12x35	77.57	102.71	1.98	1.55	1.55	2.79	10.41
HGW 45HC								128.8	171.2	28.9																	94.54	136.46	2.63	2.68	2.68	3.69	
HGW 55CC	70	13	43.5	140	116	12	95	117.7	166.7	17.35	11	12.9	M14	17.5	26.5	17	12	19	53	44	23	20	16	120	30	M14x45	114.44	148.33	3.69	2.64	2.64	4.52	15.08
HGW 55HC								155.8	204.8	36.4																	139.35	196.20	4.88	4.57	4.57	5.96	
HGW 65CC	90	15	53.5	170	142	14	110	144.2	200.2	23.1	14	12.9	M16	25	37.5	23	15	15	63	53	26	22	18	150	35	M16x50	163.63	215.33	6.65	4.27	4.27	9.17	21.18
HGW 65HC								203.6	259.6	52.8																	208.36	303.13	9.38	7.38	7.38	12.89	

Note : 1 kgf = 9.81 N

(6) Dimesions for HGR-T (Rail Mounting from Below)

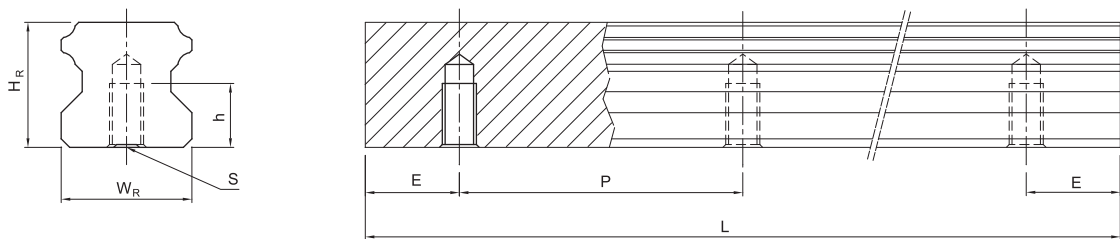

Model No.	Dimensions of Rail (mm)						Weight
	W_R	H_R	S	h	P	E	(kg/m)
HGR15T	15	15	M5 x 0.8P	8	60	20	1.48
HGR20T	20	17.5	M6 x 1P	10	60	20	2.29
HGR25T	23	22	M6 x 1P	12	60	20	3.35
HGR30T	28	26	M8 x 1.25P	15	80	20	4.67
HGR35T	34	29	M8x1.25P	17	80	20	6.51
HGR45T	45	38	M12 x 1.75P	24	105	22.5	10.87
HGR55T	53	44	M14 x 2P	24	120	30	15.67
HGR65T	63	53	M20 x 2.5P	30	150	35	21.73