

Safety Control Unit SG-EFS 1X4 ZK2/1 with automatic or manual reset

Operating Instructions

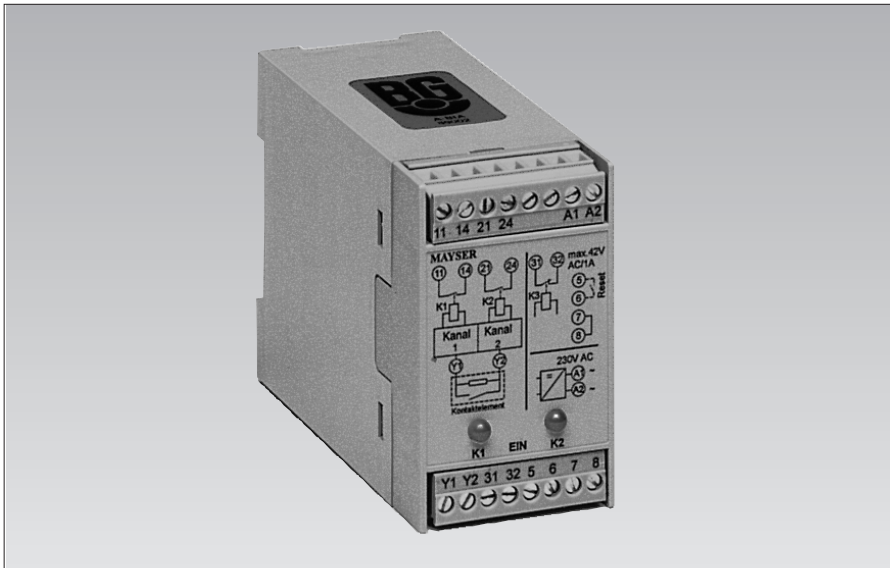

Safety Control Unit
with EEC-type-examination certificate
Category 3 per EN 954-1
with force guided contacts for
increased safety requirements;
for Pressure Sensitive Mats, Safe
Edges and Safety Bumpers with
1.2 kΩ monitoring resistor.

These operating instructions apply to
the following control units:

SG-EFS 104 ZK2/1	24 V=~/~
SG-EFS 114 ZK2/1	115 V~
SG-EFS 134 ZK2/1	230 V~

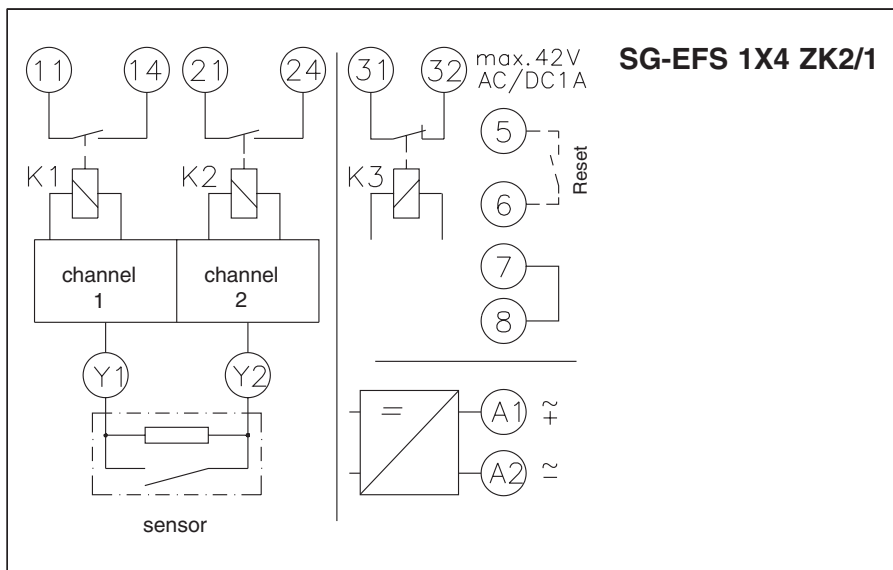

Control

The single-fault-safe electronics module has two channels (redundant). Each channel triggers a force guided relay. The relays self-test by contact return after each switching cycle. The electronics monitor the electrical resistance of the connected sensors which have a specific closed-circuit current. When the sensors are not activated, both output relays are energized and both yellow LEDs light. If a sensor is activated, or a break occurs in the supply to the control unit, relays K1 and K2 deenergize and the LEDs go out.

2 connection variants:

- SG-EFS 1X4 ZK2/1 with automatic reset

Bridge 7, 8 must be in place

The unit becomes active again as soon as the sensor is no longer activated.

The fault indicator relay K3 works in synchrony with the safety relays K1, K2 and is available as a voltage free, normally closed contact.

- SG-EFS 1X4 ZK2/1 with manual reset

Bridge 7, 8 must be removed

After deactivation of the sensor, the unit must be re-activated by means of an external reset button.

The fault indicator relay K3 works in synchrony with the safety relays K1, K2 and is available as a voltage free, normally closed contact.

Note!

Not for safety circuit:

- The fault indicator contacts across 31, 32 are solely for information purposes and must not be connected into the safety circuit.

Do not cross link SG:

- Clamps 5, 6 as well as 7, 8 and Y1, Y2 are not voltage free and thus may not be cross linked with further control units.

Safety Control Unit SG-EFS 1X4 ZK2/1

IMPORTANT NOTES!

Please read!

To ensure correct and safe operation of the unit, it must be properly transported and stored, properly installed and commissioned, and operated in accordance with its purpose.

Only persons familiar with the installation, commissioning and operation, and with the corresponding qualifications to prove their skills, may work on the units. They must observe the contents of these instructions, the notes given on the type plate of the unit and the safety requirements relevant to the

installation and operation of electrical systems.

This unit is constructed and tested to prEN 1760 and DIN V 31006 and left our factory in perfect condition with regard to safety. In order to maintain this state, you must observe the safety regulations marked "**WARNING!**" in these operating instructions. Failure to observe the safety regulations can lead to death, injury to personnel, or damage to the unit and other systems and equipment.

Should the information given in these operating instructions be inadequate in

any way, please contact your local technical centre, subsidiary or representative.

When using the device outside the European Union, you must observe the relevant regulations valid for the country of use.

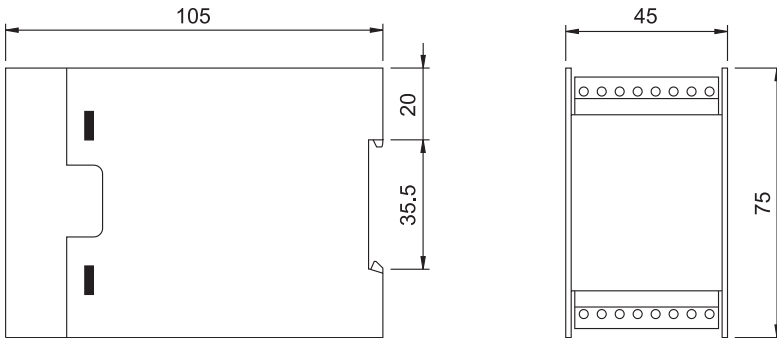

Enclosure

W x H x D (mm)	45 x 75 x 105
Protection class	IP 40
Plug-in connectors	each 8-channel
Cable clamps	max. 2.5 mm ²
Weight = model	approx. 175 g
~ model	approx. 270 g

Notes on protection class:

The units may only be used in locations with a minimum protection of IP 54 (eg. cabinet).

Technical Data

Connecting Voltage U_s

SG-EFS 104 ZK2/1	AC 24 V	DC 24 V
SG-EFS 114 ZK2/1	AC 115 V	
SG-EFS 134 ZK2/1	AC 230 V	
Voltage tolerance	-15% to +10%	-15% to +20%
Nominal frequency	50 Hz	
Frequency tolerance	48 - 62 Hz	
Power consumption	< 5 VA for AC	< 5 W for DC 28 V

Sensor Voltage DC 15 V

Relay Data

Contact load per usage category AC / DC -1

for low inductive loads

max. AC 240 V / 4 A

max. DC 24 V / 1 A

fault indicator relay

max. AC/DC 42 V / 1 A

Permissible ambient temperature - 20 °C to + 50 °C

Parts supplied

- Control unit

Enclosure with electronics module

Note

When switching inductive loads the user must be fitted out with spark absorbers.

Installation and Operation

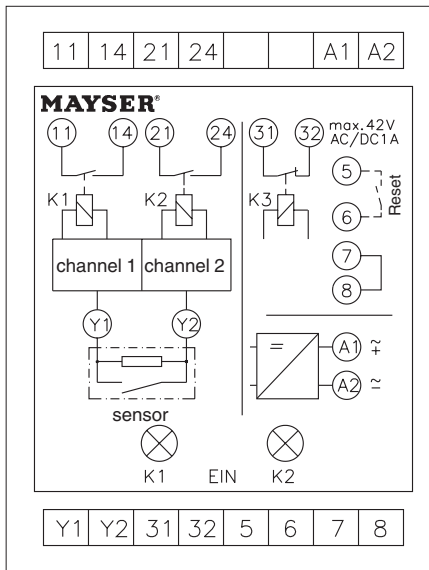

Installation

Mount the snap-on base in any position:
- on a 35 mm EN 50 022 rail

Wiring takes place in the cable clamps of the plug-in connection:

Sensor	Y1, Y2
Supply voltage	A1, A2
Switching channel 1	11, 14
Switching channel 2	21, 24
Fault indicator relay	31, 32
Reset button	5, 6
For automatic reset only:	
Bridge	7, 8

Maintenance

The control unit is maintenance free.
Check the safety installation monthly be activating the sensors.

Commissioning

After connecting up sensors, switching contacts and power, carry out a function test in the following order:

Sensor not activated

- both yellow LEDs light
- output relays K1, K2 are energized
- fault indicator relay K3 is energized

Activate sensor

- both yellow LEDs go out
- output relays K1, K2 deenergize
- fault indicator relay K3 deenergizes

WARNING!

Do not release terminals or remove the plug-in connection with power on.

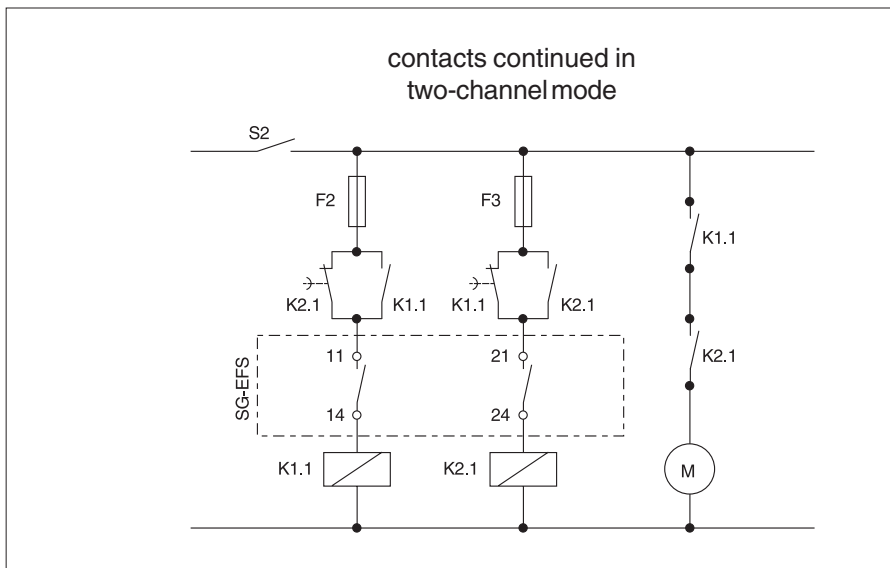

Important notes:

- **Supply voltage**
must be in accordance with the connecting voltage U_s indicated on the type plate.
- **Permissible temperature range**
maintain sufficient distance from heat sources (min. 2 cm).
- **Wiring**
Wire direct to the control circuit or continue two-channel mode to the next circuit.
Fuse the relay contacts externally (risk of welding).

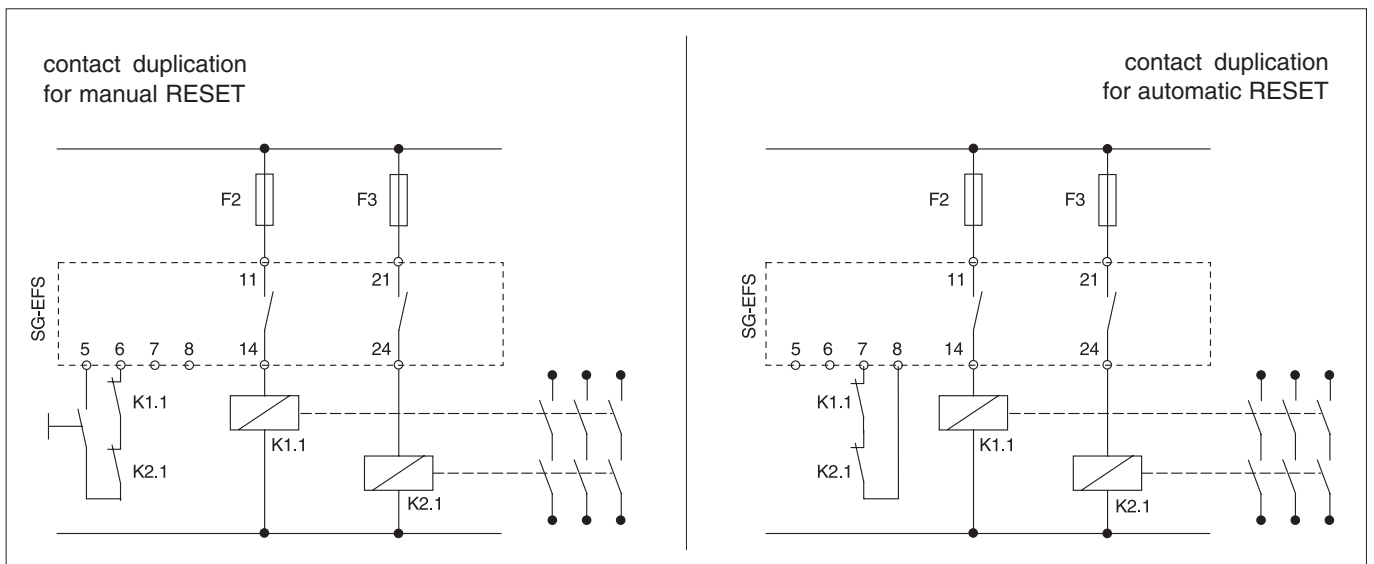

Check sensor

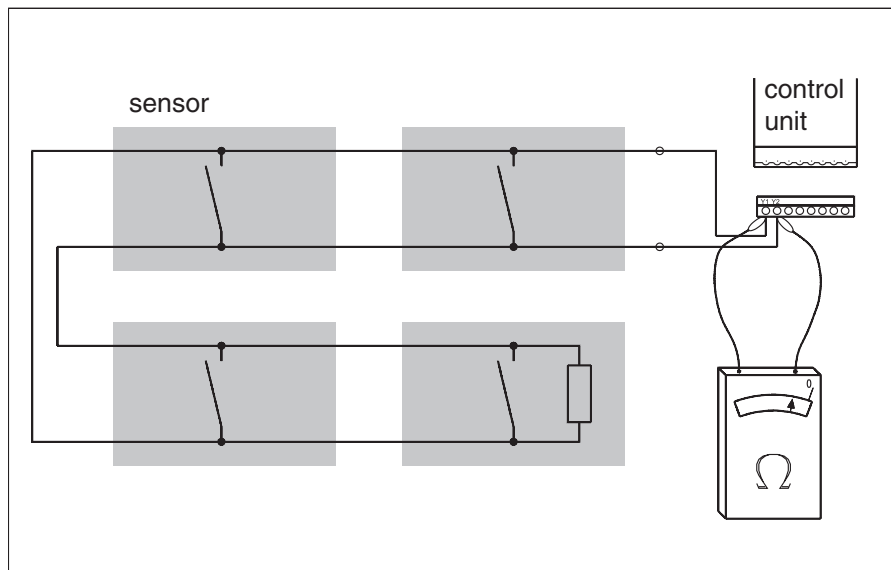

Check combination of sensors

Resistance measurement:
 Disconnect power to the unit.
 Remove plug-in connection and
 measure (Y1, Y2) with an ohmmeter:
 not activated c. 1.2 kΩ
 activated < 150 Ω

If the values measured deviate considerably from the set values, the sensors have to be checked individually (see below).

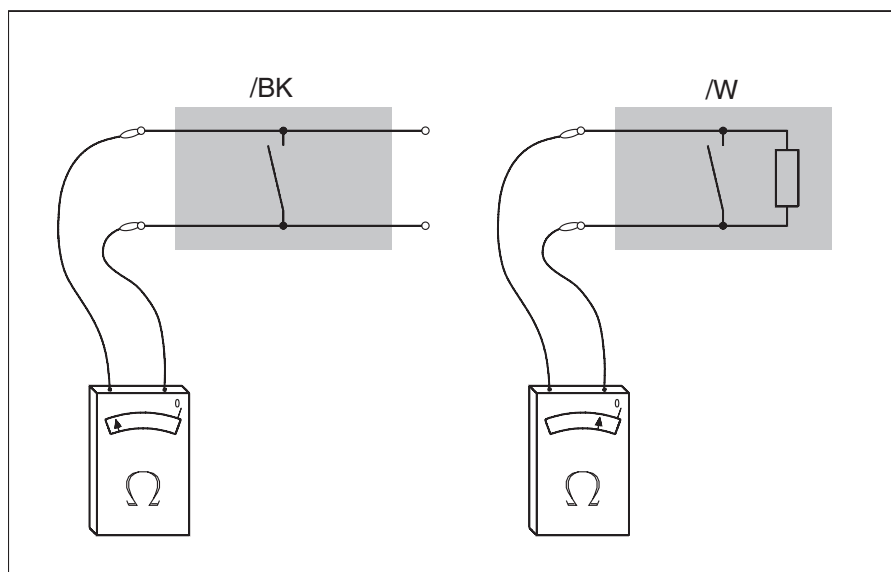

Check individual sensors

Resistance measurement:
 Measure each individual sensor with an ohmmeter :

/BK	not activated	infinite Ω
	activated	< 150 Ω
/W	not activated	c. 1.2 kΩ
	activated	< 150 Ω

Check also cables and cable connections.

Damaged or faulty sensors must be repaired or replaced immediately by a specialist.

Only a functioning system can ensure maximum safety!

Troubleshooting and remedies

Prerequisite: SG-EFS with connected, but not activated sensor and power supply.

- yellow LEDs do not light, relays have not deenergized:
 - > supply voltage off or incorrect
 - ☞ Check supply voltage, compare with type plate
 - > faulty sensor or supply lines
 (break in connection or short circuit)
 - ☞ Fit 1.2 kΩ resistor instead of sensor.
 If the yellow LEDs do not light, the control unit is faulty.
- one yellow LED lights:
 - > Fault in control unit
 Control unit faulty

Subject to technical modifications.